

OPERATOR'S AND AVIATION UNIT MAINTENANCE MANUAL

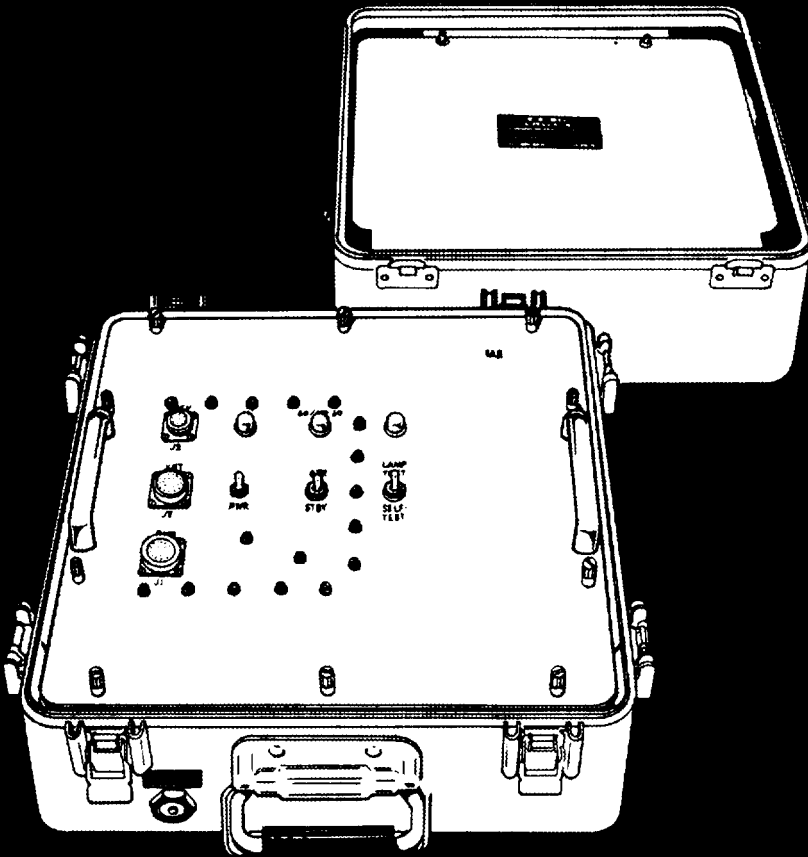

**TEST SET,
COUNTERMEASURES SET
TS-3614/ALQ-136(V)
(NSN 6625-01-121-8983)**

**EQUIPMENT
DESCRIPTION**

**OPERATING
INSTRUCTIONS**

**MAINTENANCE
INSTRUCTIONS**

**PREVENTIVE
MAINTENANCE CHECKS
AND SERVICES**

**TROUBLESHOOTING
PROCEDURES**

**MAINTENANCE
PROCEDURES**

APPENDIX

W A R N I N G

High voltage is used in the operation of this equipment. Avoid contacting high-voltage connections when installing or operating this equipment. Injury or death may result if personnel fail to observe safety precautions.

Do not be misled by the term "low voltage". Potentials as low as 50 volts may cause death under adverse conditions.

W A R N I N G

Adequate ventilation should be provided while using TRICHLOROTRI FLUOROETHANE. Prolonged breathing of vapor should be avoided. The solvent should not be used near heat or open flame; the products of decomposition are toxic and irritating. Since TRICHLOROTRI FLUOROETHANE dissolves natural oils, prolonged contact with skin should be avoided. When necessary, use gloves which the solvent cannot penetrate. If the solvent is taken internally, consult a physician immediately.

W A R N I N G

A minimum of two persons must be used in handling or lifting anything in excess of 40 pounds. Extreme care must be used in handling, to prevent injury to the individual or damage to equipment.

W A R N I N G

Never work on electronic equipment unless there is another person nearby who is familiar with the operation and hazards of the equipment and who is competent in administering first aid. When the technician is aided by operators, he must warn them about dangerous areas.

Whenever possible, the power supply to the equipment must be shut off before beginning work on the equipment. Take particular care to ground every capacitor likely to hold a dangerous potential. When working inside the equipment, after the power has been turned off, always ground every part before touching it.

Be careful not to contact high-voltage connections or 115 volts ac input connections when installing or operating this equipment.

Whenever the nature of the operation permits, keep one hand away from equipment to reduce the hazard of current flowing through the body.

Do not be misled by the term "low voltage." Potentials as low as 50 volts may cause death under adverse conditions.

For Artificial Respiration, refer to FM 21-11.

F I R S T A I D

5

SAFETY STEPS TO FOLLOW IF SOMEONE IS
THE VICTIM OF ELECTRICAL SHOCK

1

DO NOT TRY TO PULL OR GRAB THE
INDIVIDUAL

2

IF POSSIBLE, TURN OFF THE ELECTRICAL
POWER

3

IF YOU CANNOT TURN OFF THE ELECTRICAL
POWER, PULL, PUSH, OR LIFT THE PERSON
TO SAFETY USING A WOODEN POLE OR A
ROPE OR SOME OTHER INSULATING MATERIAL

4

SEND FOR HELP AS SOON AS POSSIBLE

5

AFTER THE INJURED PERSON IS FREE OF
CONTACT WITH THE SOURCE OF ELECTRICAL
SHOCK, MOVE THE PERSON A SHORT
DISTANCE AWAY AND IMMEDIATELY START
ARTIFICIAL RESUSCITATION

**OPERATOR'S AND AVIATION UNIT
MAINTENANCE MANUAL**

**TEST SET, COUNTERMEASURES SET
TS-3614/ALQ-136(V)
(NSN 6625-01-121-8983)**

REPORTING ERRORS AND RECOMMENDING IMPROVEMENTS

You can help improve this manual . If you find any mistakes or if you know of a way to improve the procedures, please let us know. Mail your letter, DA Form 2028 (Recommended Changes to Publications and Blank Forms), or DA Form 2028-2 located in the back of this manual direct to: Commander, US Army Communications-Electronics Command and Fort Monmouth, ATTN: DRSEL-ME-MP Fort Monmouth, NJ 07703.

For Navy, mail comments or OP NAV 4790/66 (TECHNICAL PUBLICATIONS DEFICIENCY REPORT) to NAVAL TECHNICAL SERVICES FACILITY, 700 Robbins Avenue, ATTN CODE 04, Philadelphia, PA 19111.

In **either** case a reply will be furnished.

	HOW TO USE THIS MANUAL	iii
CHAPTER 1	INTRODUCTION	1-1
Section I	<u>General Information</u>	1-1
II	<u>Equipment Description</u>	1-6
III	Technical Principles of Operation	1-12
CHAPTER 2	<u>OPERATING INSTRUCTIONS</u>	2-1
	Description and Use of Operator's Controls and Indicators	2-1
CHAPTER 3	<u>MAINTENANCE INSTRUCTIONS</u>	3-1
Section I	Repair Parts, Special Tools; Test, Measurement, and Diagnostic Equipment (TMDE); and Support Equipment	3-1
II	Service Upon Receipt	3-3
III	Preventive Maintenance Checks and Services	3-4
IV	Troubleshooting Procedures	3-5
V	Maintenance Procedures	3-14
VI	Preparation for Storage or Shipment	3-22
APPENDIX A.	References	A-1
APPENDIX B.	Maintenance Allocation	B-1
Section I	Introduction	B-1
II	Maintenance Allocation Chart	B-6
III	Tools and Test Equipment Requirements	B-7
IV	Remarks	B-8
APPENDIX C.	Components of End Item List	C-1
Section I	Introduction	C-1
11	Components of End Item	C-2
APPENDIX D.	Additional Authorization List (Not Applicable)	
APPENDIX E.	Expendable Supplies and Materials List	E-1
Section I	Introduction	E-1
II	Expendable Supplies and Materials	E-2
	Index	Index-1

HOW TO USE THIS MANUAL

This manual tells you about operating, and maintaining the TS-3614/ALQ-136(V) Flight Line Test Set (FLTS) at the Aviation Unit Maintenance (AVUM) level. You'll find descriptions as well as operational level maintenance instructions for the FLTS.

Operators should also consult TM 11-5865-202-12 for Countermeasures Set AN/ALQ-136(V)1 instructions concerning operation of this equipment.

For your convenience, this manual has been divided into chapters, sections, and paragraphs which are numbered sequentially. In addition to this numbering system, a system of captions appears in BROWN print to help quickly find the information you need. These captions name the pieces of equipment and/or maintenance procedures that you will be doing. Some of the procedures may consist of several smaller procedures. The captions for these smaller procedures appear under the larger ones; both appear on each page as they are continued. Each large section begins with a "Section Contents" which lists the procedures by title and page number. Tables are numbered sequentially by chapter; illustrations are integrated into the text to which they apply.

NO ONE EVER REPAIRED OR TESTED
ELECTRONIC EQUIPMENT WITHOUT FIRST
READING THE OPERATION AND
MAINTENANCE MANUAL.

IT IS THE MOST
IMPORTANT TOOL
YOU HAVE !!!



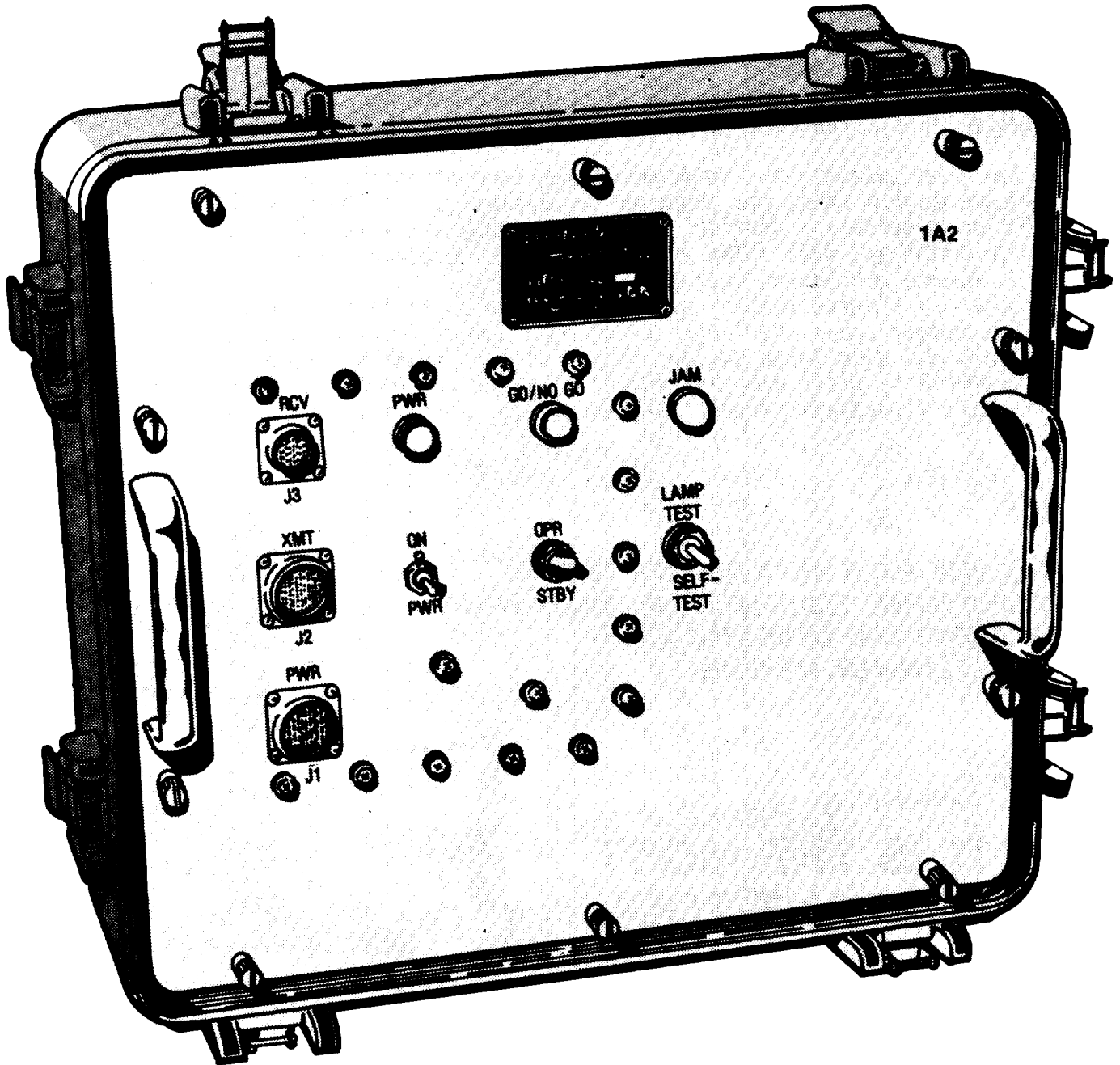

FLTS VIDEO ASSEMBLY 1A2

CHAPTER I INTRODUCTION

SECTION I GENERAL INFORMATION

<u>SECTION CONTENTS</u>	<u>PAGE</u>
SCOPE	1-1
CONSOLIDATED INDEX OF ARMY PUBLICATIONS AND BLANK FORMS	1-2
MAINTENANCE FORMS , RECORDS, AND REPORTS	1-2
HAND RECEIPT (-HR) MANUAL	1-2
REPORTING EQUIPMENT IMPROVEMENT RECOMMENDATIONS (EIR)	1-3
DESTRUCTION OF ARMY ELECTRONICS MATERIEL TO PREVENT ENEMY USE	1-4
PREPARATION FOR STORAGE OR SHIPMENT	1-4
NOMENCLATURE CROSS-REFERENCE LIST	1-4
LIST OF ABBREVIATIONS	1-5

SCOPE

1-1. This is one of a series of technical manuals covering the operation and maintenance of the AN/ALQ-136(V)1 Countermeasures Set. It is to be used by Aviation Unit Maintenance (AVUM) personnel responsible for maintaining the AN/ALQ-136(V)1.

This manual contains physical and functional descriptions, maintenance procedures, and instructions for inspection and servicing.

Model Number and
Equipment Name: Test Set, Countermeasures Set TS-3614/ALQ-136(V).

Purpose of
Equipment: To test Countermeasures Set AN/ALQ-136(V)1 without removing it from aircraft.

CONSOLIDATED INDEX OF ARMY PUBLICATIONS AND BLANK FORMS

1-2. Refer to the latest issue of DA Pam 310-1 to determine whether there are new editions, changes or additional publications pertaining to the equipment.

MAINTENANCE FORMS, RECORDS, AND REPORTS

1-3.

a. Reports of Maintenance and Unsatisfactory Equipment. Department of the Army forms and procedures used for equipment maintenance will be those prescribed by DA PAM 738-750 as contained in Maintenance Management Update. Navy personnel will report maintenance performed utilizing the Maintenance Data Collection Subsystem (MDCS) IAW OPNAVINST 4790.2, Vol 3 and unsatisfactory material/conditions (UR submissions) IAW OPNAVINST 4790.2, Vol 2, chapter 17.

b. Report of Packaging and Handling Deficiencies. Fill out and forward SF 364 (Report of Discrepancy [ROD]) as prescribed in AR 735-11-2/DLAR 4140.55/NAVMATINST 4355.73/AFR 400-54/MCO 4430.3E.

c. Discrepancy in Shipment Report (DISREP) (SF 361). Fill out and forward Discrepancy in Shipment Report (DISREP) (SF 361) as prescribed in AR 55-38/NAVSUPINST 4610.33B/AFR 75-18/MCO P4610.19C/DLAR 4500.15.

HAND RECEIPT (-HR) MANUAL

1-4. This manual has a companion document with a TM number followed by "-HR" (which stands for Hand Receipt). TM 11-6625-2885-12-HR consists of preprinted hand receipts (DA Form 2062) that list end item related equipment (i.e., COEI, BII and AAL) you must account for. As an aid to property accountability, additional -HR manuals may be requisitioned from The US Army Adjutant General Publications Center, Baltimore, MD 21220 in accordance with procedures in Chapter 3, AR 310-2, and DA Pam 310-10-2.

REPORTING EQUIPMENT IMPROVEMENT RECOMMENDATIONS (EIR)

1-5.

a. Army. If your flight line test set needs improvement, let us know. Send us an EIR. You, the user, are the only one who can tell us what you don't like about your equipment. Let us know why you don't like the design. Put it on an SF 368 (Quality Deficiency Report). Mail it to Commander, US Army, Communications - Electronics Command and Fort Monmouth ATTN: DRSEL-ME-MP, Fort Monmouth, New Jersey 07703. We'll send you a reply.

b. Navy. Navy personnel are encouraged to submit EIR's through their local Beneficial Suggestion Program.

<i>Carbon paper is required - only face of form is chemical treated</i>	
SECTION III	
27a. From (Action point)	27a. To (Screening point)
27b. Typed Name, Duty Phone and Signature	27b. Typed Name, Duty Phone and Signature

DO NOT DETACH THIS STUB ON COPIES FORWARDED TO SCREENING AND ACTION POINTS <i>Carbon paper not required to complete this side.</i>	
QUALITY DEFICIENCY REPORT (Category II)	
SECTION I	
1a. From (Originating point)	1a. To (Screening point)
1b. Typed Name, Duty Phone and Signature	1b. Typed Name, Duty Phone and Signature

Phone Call/Visit
 (Specify)

STANDARD FORM 368, April 1974
 General Services Administration (FPMR 101-26-7)

DESTRUCTION OF ARMY ELECTRONICS
MATERIEL TO PREVENT ENEMY USE

1-6. Destruction of Army electronics materiel to prevent enemy use shall be in accordance with TM 750-244-2.

PREPARATION FOR STORAGE OR SHIPMENT

1-7.

a. Refer to Chapter 3, Section VI of this manual for instruction for preparing the FLTS for storage or shipment, including packaging and administrative storage.

b. Administrative Storage of equipment issued to and used by Army activities will have preventive maintenance performed in accordance with the PMCS charts before storing. When removing the equipment from administrative storage the PMCS should be performed to assure operational readiness. Disassembly and repacking of equipment for shipment or limited storage are covered in paragraphs 3-14 and 3-15.

NOMENCLATURE CROSS-REFERENCE LIST

1-8.

<u>OFFICIAL NAME</u>	<u>COMMON NAME</u>	<u>COMMON ABBREVIATION</u>
Countermeasures Set AN/ALQ-136(V)1	Countermeasures set	CM set
Receiver-Transmitter, Countermeasures Set RT-1149(V)1/ALQ-136(V)	Receiver-transmitter	LRU-1
Antenna AS-3007/ALQ-136(V)	Receive antenna	LRU-2A
Antenna AS-3007/ALQ-136(V)	Transmit antenna	LRU-2B
Control, Countermeasures Set C-9576/ALQ	Operator's control unit (RDR CM part of OCU)	OCU or LRU-3 (OCU-R)
Test Set, Countermeasures Set TS-3614/ALQ-136(V)	Flight line test set	FLTS
Test Set, Countermeasures Set TS-3615/ALQ-136(V)	Bench test set	BTS

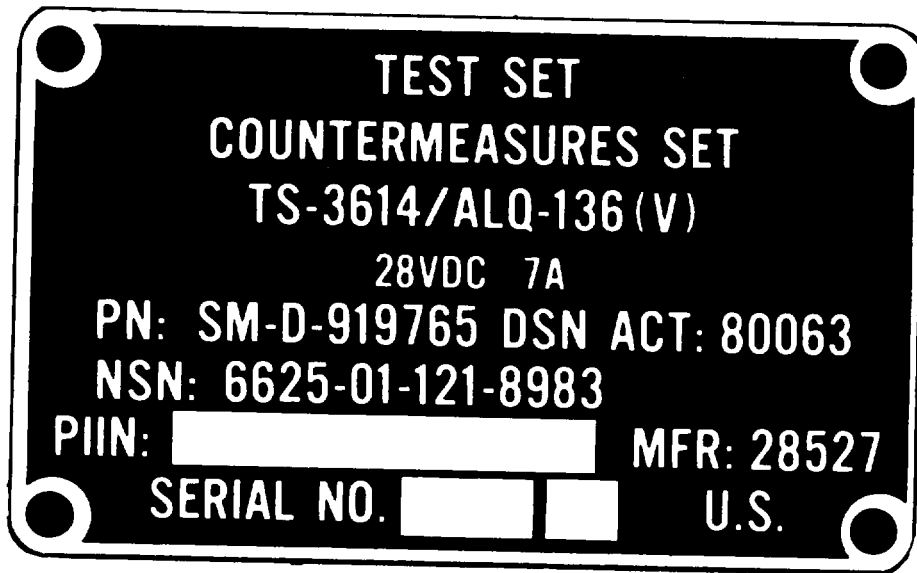

1-9.

LIST OF ABBREVIATIONS

<u>ABBREVIATION</u>	<u>DESCRIPTION</u>
ac	alternating current
°C	degrees Celsius
ccw	counterclockwise
cm	centimeter
CM set	countermeasures set
cw	clockwise
dc	direct current
DS	direct support
°F	degrees Fahrenheit
FLTS	flight line test set
GS	general support
Hz	Hertz
IR	infrared
IRCM	infrared countermeasures
INOP	inoperative
LRU	line replaceable unit
MAC	maintenance allocation chart
MM	multimeter
OCU	operator's control unit
OCU-R	radar CM section of OCU
OPR	operate
PMCS	preventive maintenance checks and services
STBY	standby
TM	technical manual
UUT	unit under test
V	volts
YIG filter	Yttrium Iron Garnet filter

SECTION II
EQUIPMENT DESCRIPTION

<u>SECTION CONTENTS</u>	<u>PAGE</u>
EQUIPMENT CHARACTERISTICS, CAPABILITIES, AND FEATURES	1-6
LOCATION AND DESCRIPTION OF MAJOR COMPONENTS	1-7
EQUIPMENT DATA	1-10
SAFETY, CARE, AND HANDLING	1-11

EQUIPMENT CHARACTERISTICS, CAPABILITIES AND FEATURES

1-10. The FLTS is used to test Countermeasures Set AN/ALQ-136(V)1 (CM set) in an aircraft. It provides a rapid GO/NO-GO indication of the CM set's functional status. All controls, indicators, and circuits necessary to perform a GO/NO-GO test of an installed CM set are included in the FLTS.

THE FLTS

- Transmits a simulated radar (RF) test signal to the CM set.
- Receives modulated RF response signals from CM set.
- Analyzes and presents visual GO indication when CM set is responding correctly.
- Lightweight design permits testing of CM set on the aircraft.
- Cover space permits transporting all necessary hook-up cables and accessory antenna assemblies in one convenient package.
- Self-test feature permits testing its own operation at the aircraft.

LOCATION AND DESCRIPTION OF MAJOR COMPONENTS

1-11. The FLTS consists of the following assemblies:

- | | |
|-----------------------------------|----------------------------|
| 1 Video assembly 1A2 | 5 Cable assembly W3 |
| 2 Case cover | 6 Cable assembly W2 |
| 3 Receiver assembly 1A3 | 7 Cable assembly W4 |
| 4 Transmitter assembly 1A1 | 8 Cable assembly W1 |

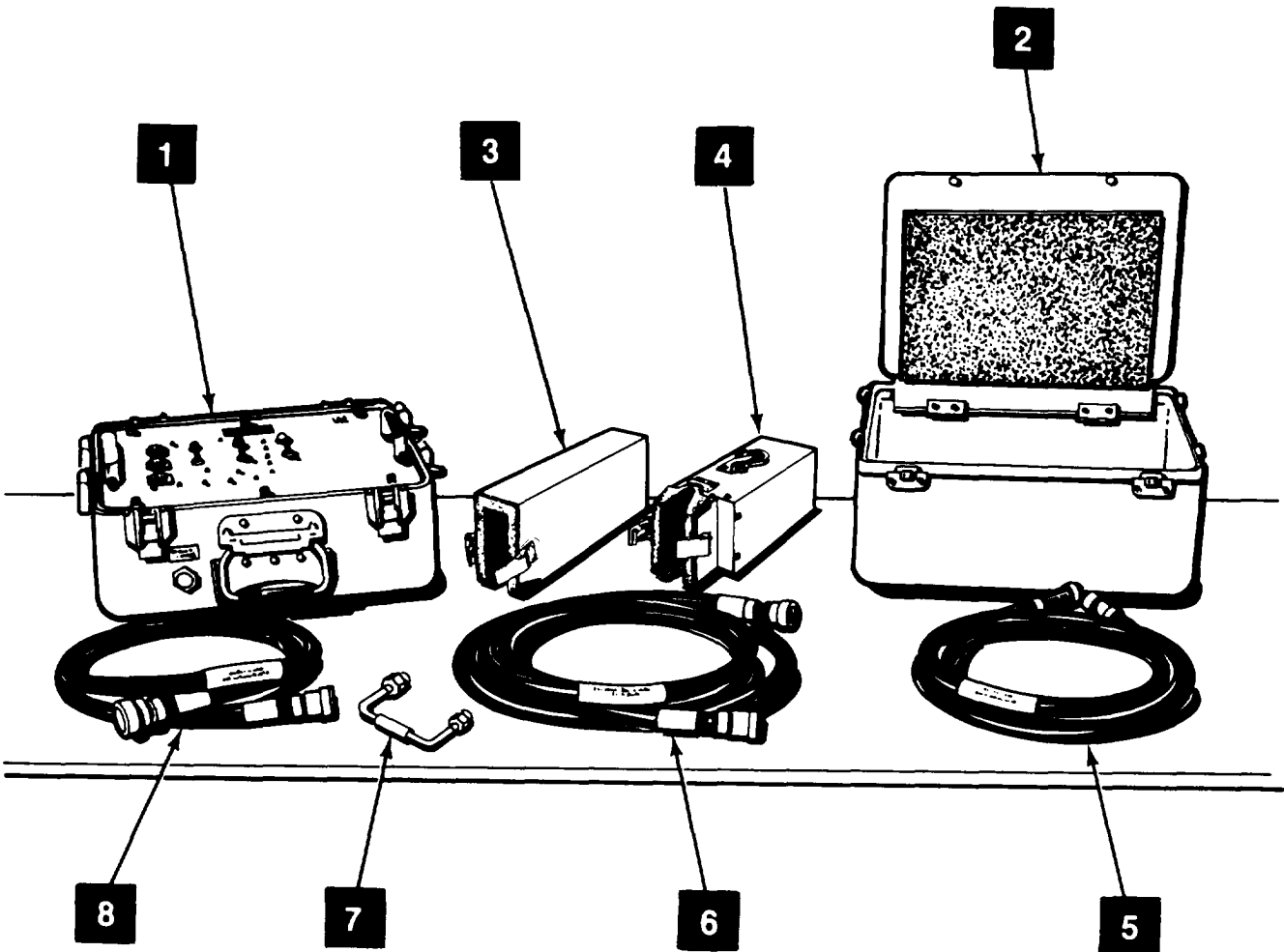

LOCATION AND DESCRIPTION OF MAJOR COMPONENTS (Continued)

1 VIDEO ASSEMBLY Video assembly 1A2 contains the operational controls and indicators. It consists of a front panel assembly and power supplies mounted in the bottom part of the combination case.

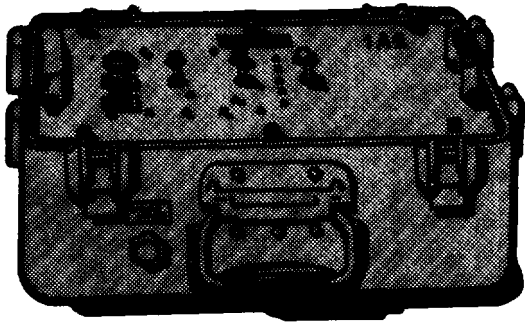

2 CASE COVER Stores other components.

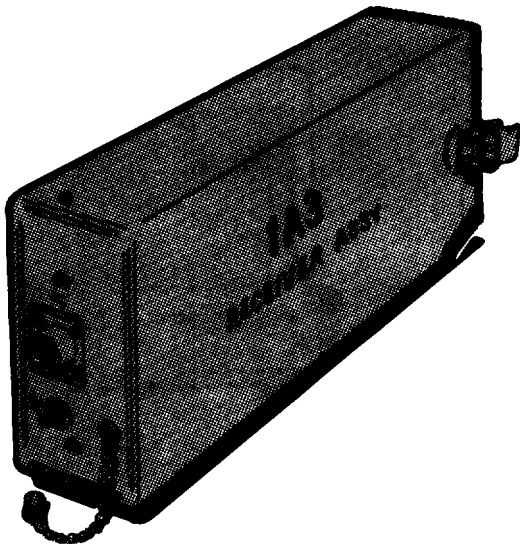
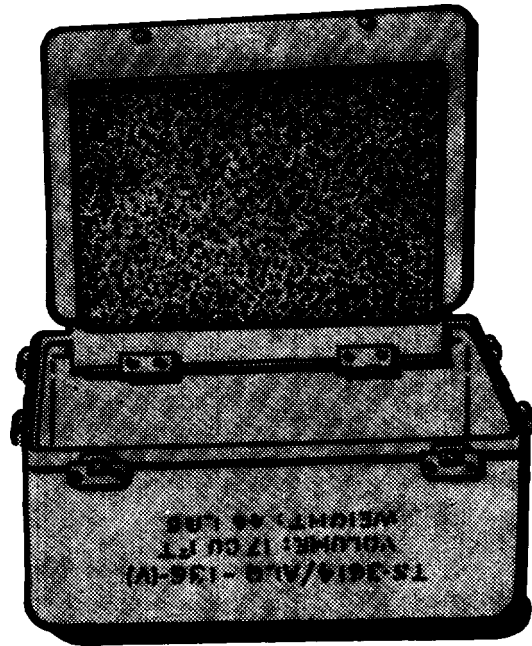

3 RECEIVER ASSEMBLY Receiver assembly 1A3 is a removable separate weatherproof assembly stored in the cover of the combination case. The receiver assembly contains the receiver antenna, associated RF components, and circuits.

4 TRANSMITTER ASSEMBLY Transmitter assembly 1A1 is a removable separate weatherproof assembly stored in the cover of the combination case. The transmitter assembly contains the transmit antenna, associated RF components, and circuits.

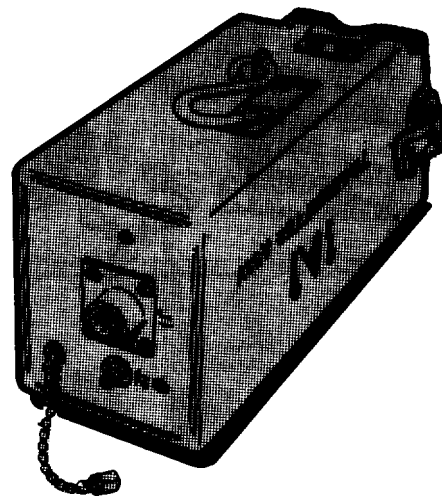

5 CABLE ASSEMBLY W3 Cable assembly W3 connects power and functional signals between FLTS receiver assembly 1A3 and FLTS video assembly 1A2. Length - 11 ft (3.3 m).

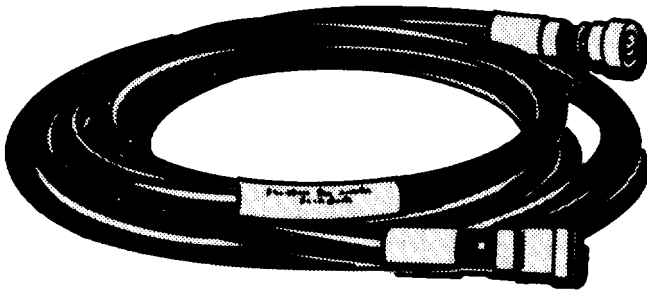
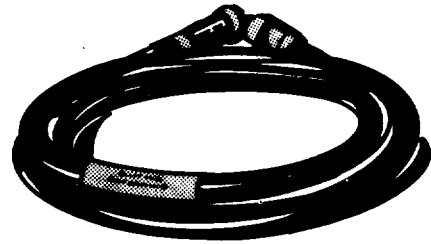

6 CABLE ASSEMBLY W2 Cable assembly W2 connects power and RF control signals between video assembly 1A2 and transmitter assembly 1A1. Length - 10.5 ft (3.2 m).

7 CABLE ASSEMBLY W4 Cable assembly W4 connects transmitter assembly 1A1 to receiver assembly 1A3 during SELF-TEST only.

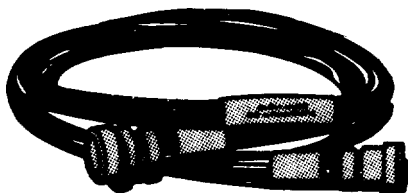
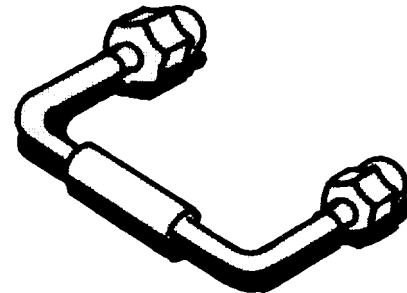

8 CABLE ASSEMBLY W1 Cable assembly W1 connects power and functional signals between the CM set and FLTS video assembly 1A2. Length 6.5 ft (1.96 m).

EQUIPMENT DATA

1-12. The following additional data apply to the FLTS and its operational requirements:

Power Requirements	+28 V (+24 to +29 V) supplied through LRU-1 of the AN/ALQ-136(V)1 from auxiliary power. Maximum power is 203W.	
Transmit Output Frequency	F4 (This information is security classified.) Refer to technical data for AN/ALQ-136(V)1.	
Transmit Output Power	+3 dBm minimum.	
Transmit Output PRI's (pulse repetition interval)	350 ± 35 μs and 100 + 10 μs.	
Transmit Pulse Width	0.3 + 0.1 μs.	
Dimensions	Height:	12.25 in. (31 cm)
	Width:	16.12 in. (41 cm)
	Depth:	14.62 in. (37 cm)
Weight	46 lb. (21 kg)	

<u>Temperatures:</u>	<u>°F</u>	<u>°C</u>
Operating	-40 to +131	-40 to +55
Storage	-67 to +160	-55 to +71

SAFETY, CARE, AND HANDLING

1-13. Observe all WARNINGS given in this manual on the inside front cover, and again before every operation which may be dangerous to personnel. The CM set to be tested by this equipment is a highly accurate system designed to save the lives of the users and must be kept in a state of high operating efficiency. The FLTS is a delicate piece of electronic equipment and, though constructed ruggedly to withstand shock of normal operation, must be handled with appropriate care.

SECTION III
TECHNICAL PRINCIPLES OF OPERATION

BLOCK DIAGRAM DESCRIPTION

1-14. This section gives you a block diagram keyed to a functional description of the FLTS.

- 1** Video assembly 1A2 receives video signals from the FLTS receiver assembly. It generates modulating signals and transmits them to the FLTS transmitter assembly. During self-test it controls the test and visually indicates results.
- 2** Receiver assembly 1A3 receives an RF signal from the CM set, detects the RF power threshold and routes it to video assembly 1A2.
- 3** Transmitter assembly 1A1 furnishes the CM set receive antenna with an RF signal modulated with the video signals generated in the video assembly.
- 4** Operating power and functions are furnished to the FLTS directly from LRU-1.

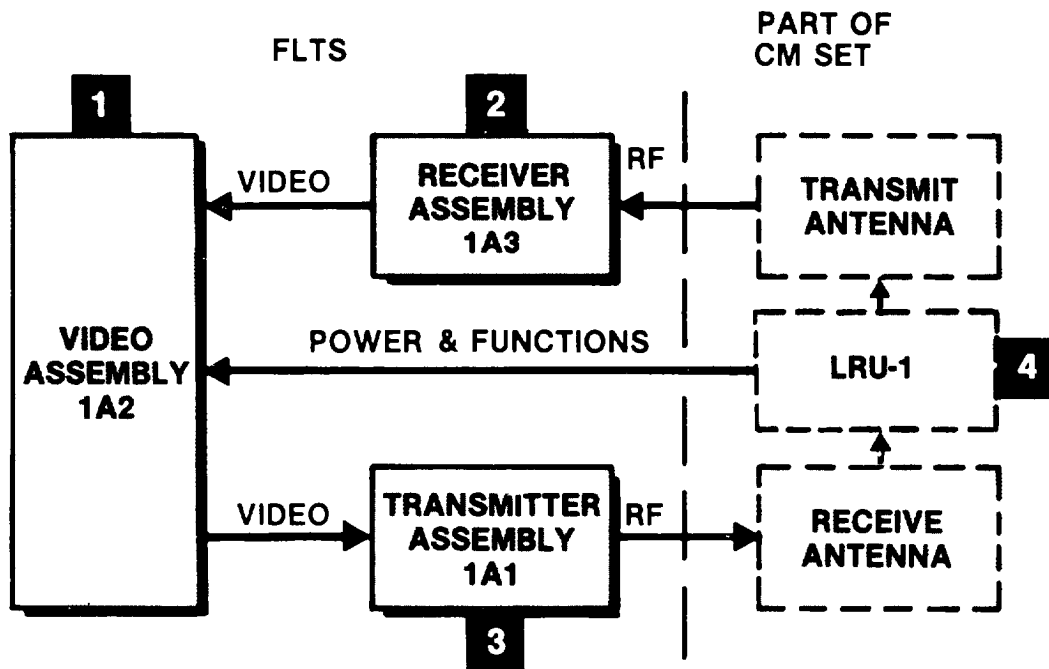

CHAPTER 2

OPERATING INSTRUCTIONS

DESCRIPTION AND USE OF OPERATOR'S CONTROLS
AND INDICATORS

<u>SECTION CONTENTS</u>	<u>PAGE</u>
GENERAL	2-1
FLIGHT LINE TEST SET (FLTS) CONTROLS, INDICATORS, AND CONNECTORS.	2-2

GENERAL

2-1. To use and maintain the flight line test set (FLTS) correctly, it is important that you learn where the controls and indicators are and how they function. For example, beside learning where the controls are located and their overall function in the set, you must know how to operate the FLTS controls and properly read the indicators. The following pages identify and explain the important controls and indicators of the FLTS video assembly. The use of the controls during CM set testing is described in the CM set technical manual.



FLIGHT LINE TEST SET (FLTS) CONTROLS, INDICATORS, AND CONNECTORS

2-2. As discussed previously, the FLTS allows you to test the CM set at the flight line, and shows you the operating status of the CM set.

- 1** RCV J3 connector - connects FLTS video assembly 1A2 to FLTS receiver assembly 1A3 via cable W3.
- 2** XMT J2 connector - connects FLTS video assembly 1A2 to FLTS transmitter assembly 1A1 via cable W2.
- 3** PWR indicator - when lit (green), indicates that +28V is supplied to video assembly 1A2 power supplies.
- 4** GO/NO-GO indicator - when lit (green) indicates proper signal processing between FLTS receiver (1A3), transmitter (1A1), and video (1A2) assemblies during self-test, or between FLTS and CM set during equipment test.
- 5** JAM indicator - when lit (white), indicates that the RF power has reached an acceptable level in either self-test or equipment test.
- 6** LAMP TEST/SELF-TEST switch - momentary switch that allows selection of LAMP TEST or SELF-TEST and is in the center (off) position when no test is required. In LAMP TEST position the GO/NO-GO and JAM lamps illuminate. In SELF-TEST position signals are generated to check proper signal processing between receiver (1A3), transmitter (1A1), and video (1A2) assemblies.
- 7** OPR/STBY switch - allows selection of STBY mode or OPR mode. In STBY mode no test signal is generated. In OPR mode a test signal is generated for either self-test or equipment test.
- 8** ON/PWR circuit breaker - allows application of +28V to the FLTS in the ON position, and provides overcurrent protection.
- 9** PWR J1 connector - connects FLTS video assembly 1A2 to CM set 1J7 through cable W1.

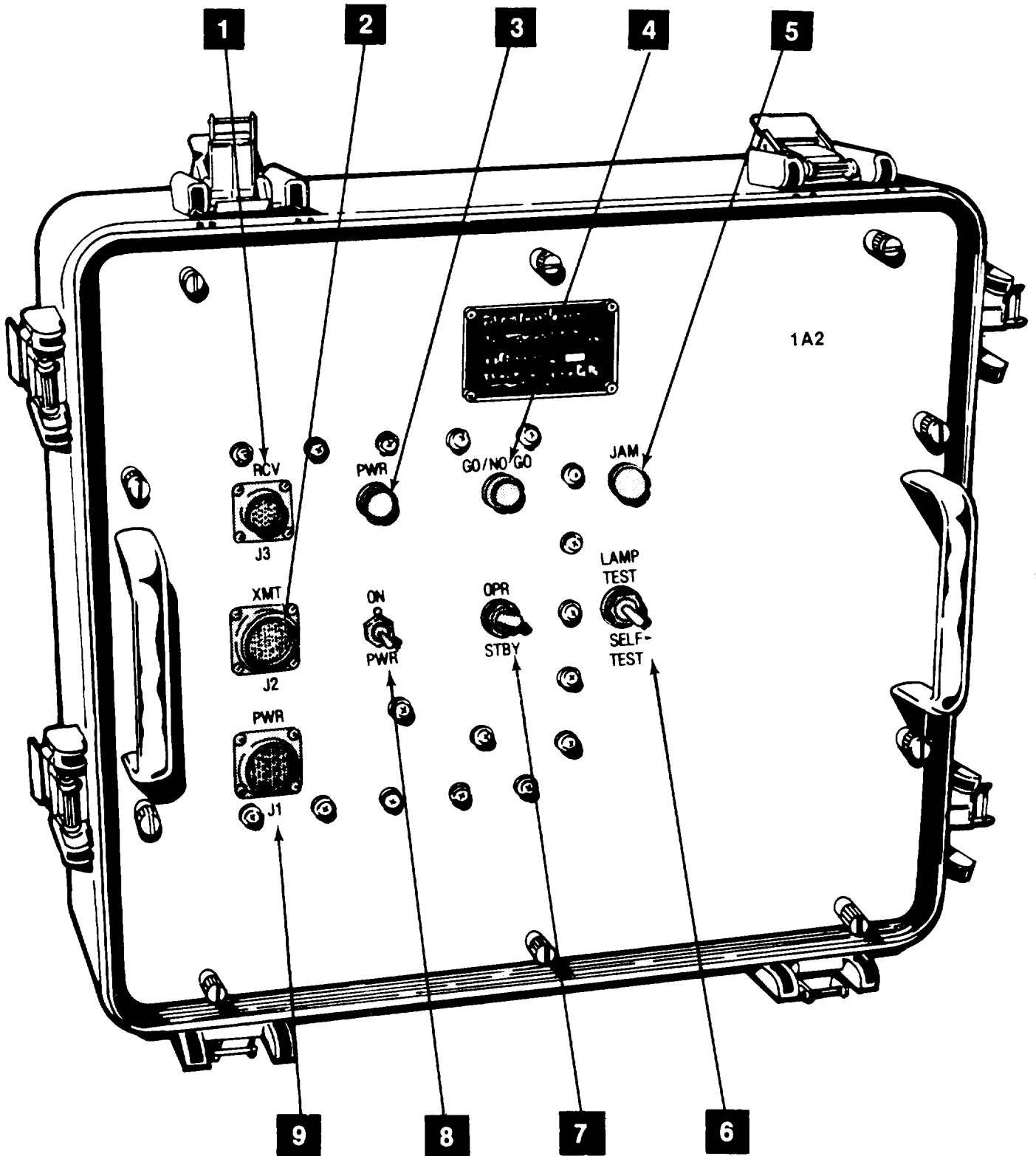

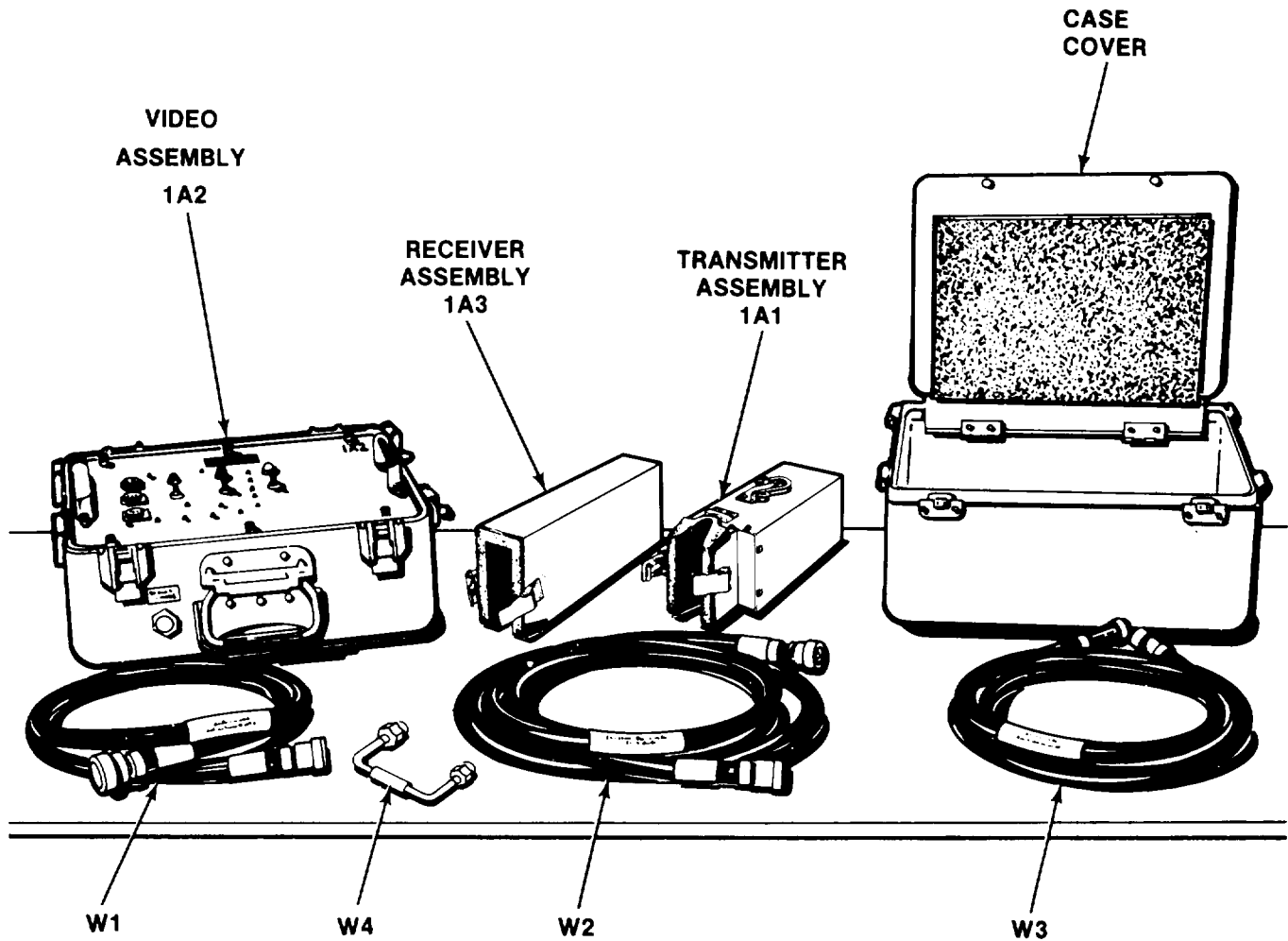

TEST SET, COUNTERMEASURES SET
TS-3614/ALQ-136(V)
(FLIGHT LINE TEST SET)

CHAPTER 3

MAINTENANCE INSTRUCTIONS

SECTION I

REPAIR PARTS, SPECIAL TOOLS; TEST, MEASUREMENT,
AND DIAGNOSTIC EQUIPMENT (TMDE);
AND SUPPORT EQUIPMENT

<u>SECTION CONTENTS</u>	<u>PAGE</u>
COMMON TOOLS AND EQUIPMENT.....	3-1
SPECIAL TOOLS, TMDE, AND SUPPORT EQUIPMENT	3-1
REPAIR PARTS.....	3-1

COMMON TOOLS AND EQUIPMENT

3-1. For authorized common tools and equipment, refer to the Modified Table of Organization and Equipment (MTOE) applicable to your unit.

SPECIAL TOOLS, TMDE, AND SUPPORT EQUIPMENT

3-2. There are no tools or support equipment required at the AVUM level , other than those listed in the MAC.

REPAIR PARTS

3-3. Repair parts are listed and illustrated in the Organizational Maintenance Repair Parts and Special Tools List for Test Set, Countermeasures Set TS-3614/ALQ-136(V) (NSN 6625-01-121-8983), TM 11-6625-2885-20P.

SECTION II

SERVICE UPON RECEIPT

<u>SECTION CONTENTS</u>	<u>PAGE</u>
UNPACKING	3-3
CHECKING UNPACKED EQUIPMENT	3-3

UNPACKING

3-4. Save the container for future shipment. The equipment is normally stored, when not in use, in its combination case. The FLTS is not classified and requires no special handling. Unpack as follows:

- 1** Open container in which FLTS is shipped.
- 2** Remove FLTS from container.

CHECKING UNPACKED EQUIPMENT

3-5. Check unpacked equipment as follows.

a. Inspect the equipment for damage incurred during shipment. If the equipment has been damaged, report the damage on SF 364 as listed in paragraph 1-2.

b. Check the equipment against the component listing on the packing list to ensure that the shipment is complete. Report all discrepancies in accordance with the instructions of TM 38-750. The equipment should be placed in service even though a minor assembly or part that does not affect proper functioning is missing.

c. Check whether the equipment has been modified. (Equipment which has been modified will have the MWO number on the front panel, near the nomenclature plate.) Also check whether all currently applicable MWO'S have been applied. (current WO'S applicable to the equipment are listed in DA Pam 310-1.)

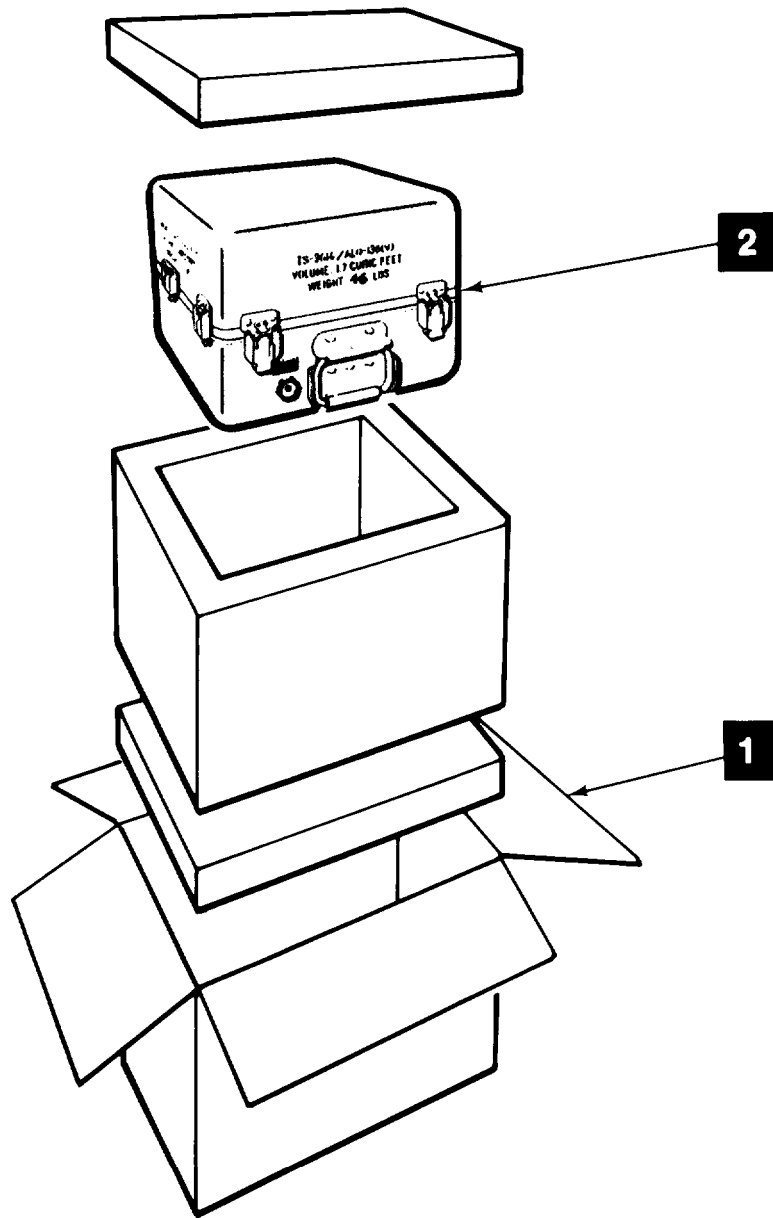

UNPACKING FLTS

SECTION III
PREVENTIVE MAINTENANCE CHECKS AND SERVICES

GENERAL

3-6. There are no scheduled periodic checks. Troubleshooting and maintenance procedures are found in Section IV and V.

Routine maintenance tasks such as cleaning, dusting, checking for frayed or loose cables, covering unused receptacles, storing items not in use, checking for loose nuts and bolts, etc. are not scheduled on a periodic basis and should be accomplished whenever you consider it necessary.

SECTION IV
TROUBLESHOOTING PROCEDURES

<u>SECTION CONTENTS</u>	<u>PAGE</u>
GENERAL.....	3-4
TROUBLESHOOTING CHART.....	3-5
CABLE INFORMATION.....	3-10

GENERAL

3-7. Troubleshooting required at the AVUM level consists of running the operational self-test, replacing lamps and doing continuity tests on cables. The following procedures will aid you in isolating the trouble to the proper corrective action. Malfunctions are listed in the same order as they may occur in the operational self-tests of paragraph 3-11.

- MALFUNCTION - This column lists the fault you observed when performing your PMCS procedures.
- TEST OR INSPECTION - This column directs you to the probable area causing the malfunction.
- CORRECTIVE ACTION - This column tells you what to do to correct the problem.

STEP MALFUNCTION

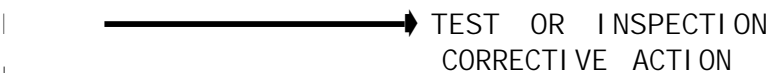

TROUBLESHOOTING CHART

3-8 The troubleshooting chart which follows is for your use as the AVUM technician.

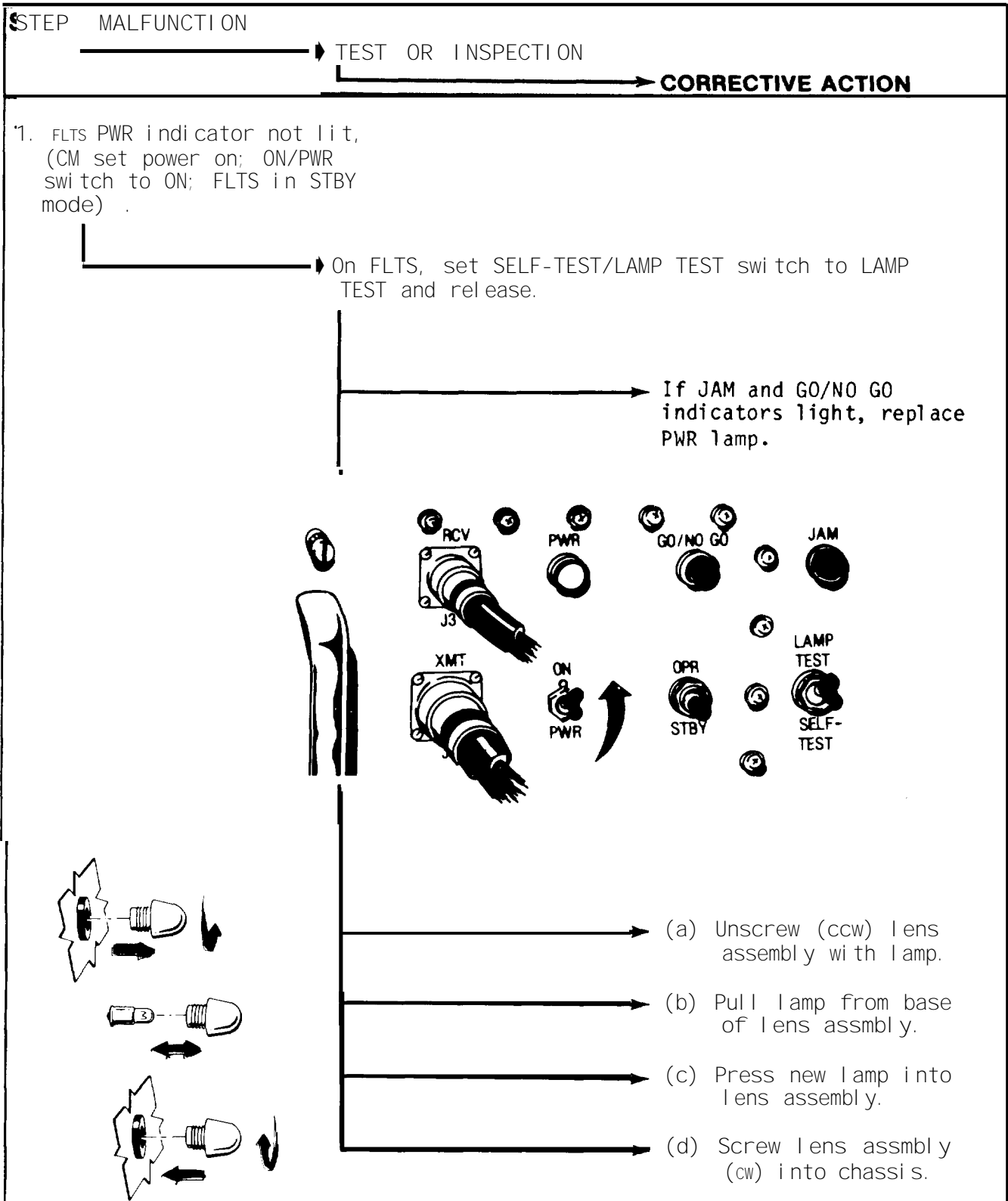

TROUBLESHOOTING CHART (Continued)

STEP TEST OR	MALFUNCTION OR	INSPECTION CORRECTIVE	ACTION
1. (Continued)		<p>If JAM and GO/NO GO indicators do not light, disconnect FLTS end of FLTS cable W1; test for +28 V from pin 1 to pin 4.</p> <p>(a) If +28 V is present, replace FLTS.</p> <p>(b) If +28 V is not present disconnect FLTS cable W1 from LRU-1 (1J7). Check for bent pins.</p>	<p>(c) Referring to page 3-10, test FLTS cable W1 for continuity between W1P1-83 to W1P2-1, and W1P1-64 to W1P2-4.</p> <p>(1) If cable lead open, replace cable.</p> <p>(2) If cable lead not open, refer to CM set technical manual and troubleshoot CM set.</p>

STEP MALFUNCTION

TEST OR INSPECTION
CORRECTIVE ACTION

2. GO/NO GO or JAM indicator fails to light during LAMP TEST.

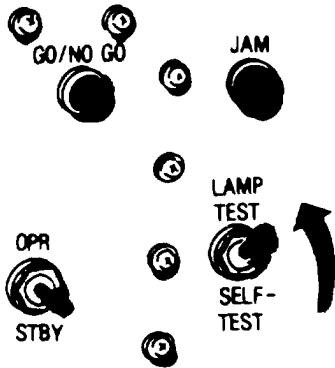
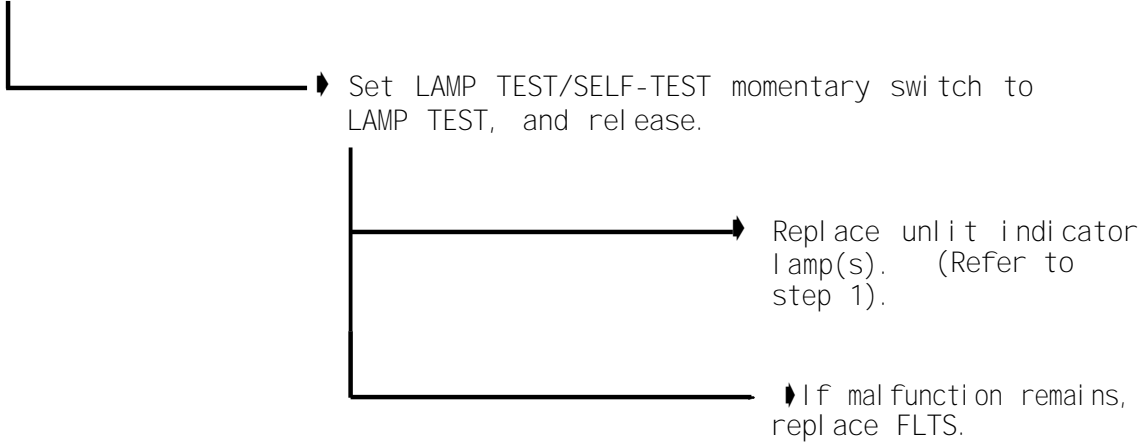

TROUBLESHOOTING CHART (Continued)

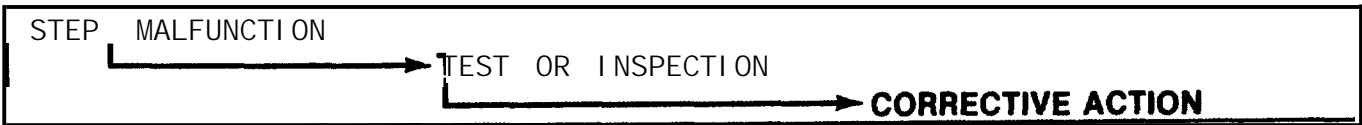

3. GO/NO GO or JAM indicator fails to light during FUNCTIONAL SELF TEST.

Set STBY/OPR switch to OPR.

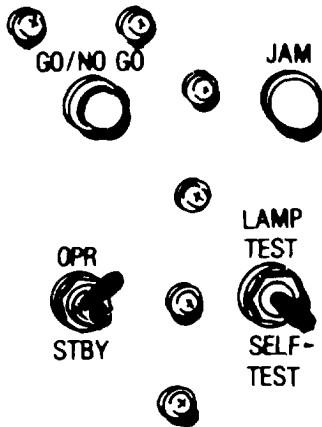

Set LAMP TEST/SELF TEST toggle to SELF-TEST position.

a. JAM indicator NOT lit, GO/NO GO indicator lit.

Replace FLTS JAM indicator.

Set CM set power off; Replace FLTS.

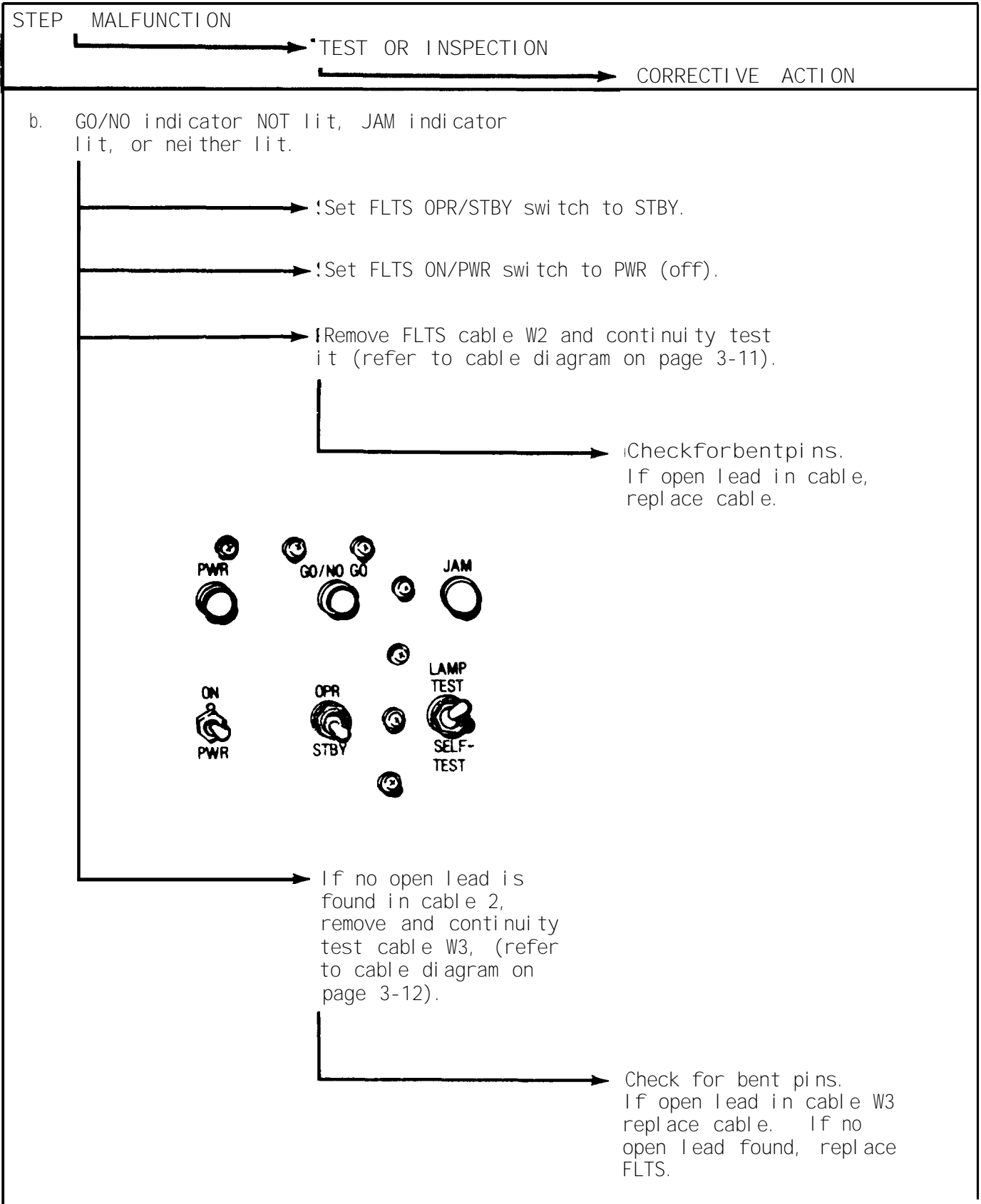

CABLE INFORMATION

3-9. Use following cable schematics to check cable continuity.

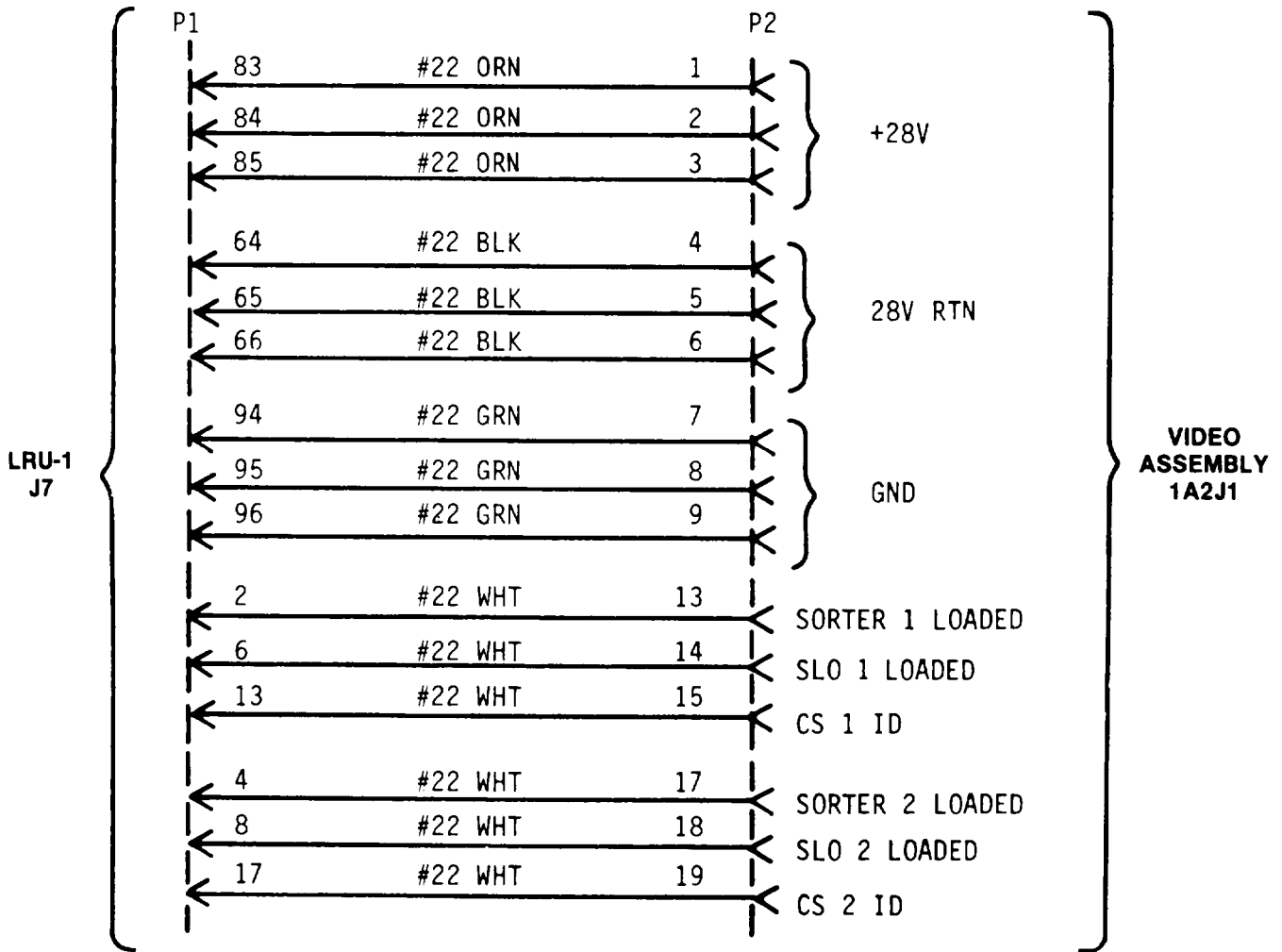

FLTS CABLE W1

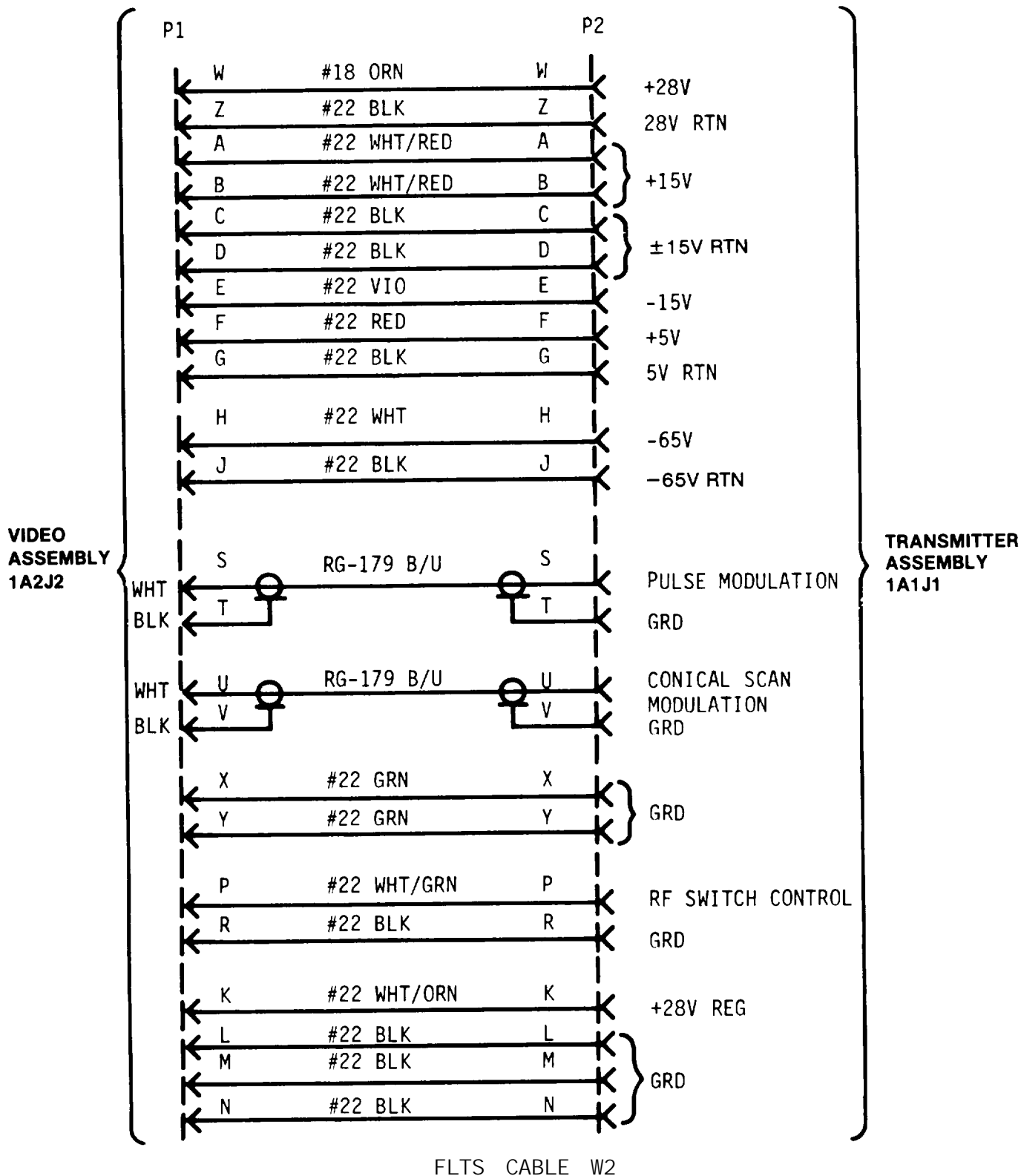

CABLE INFORMATION (Continued)

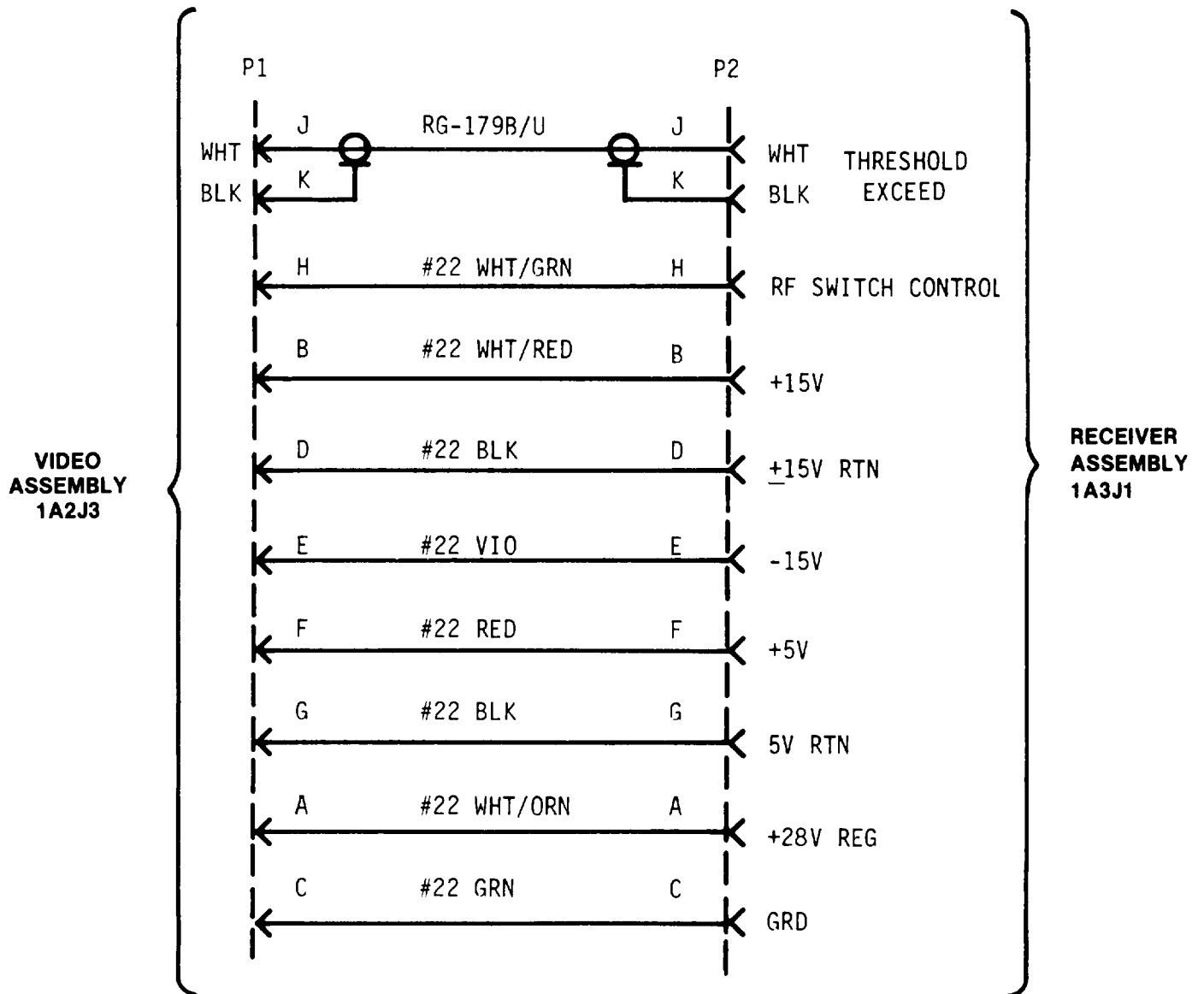

FLTS CABLE W3

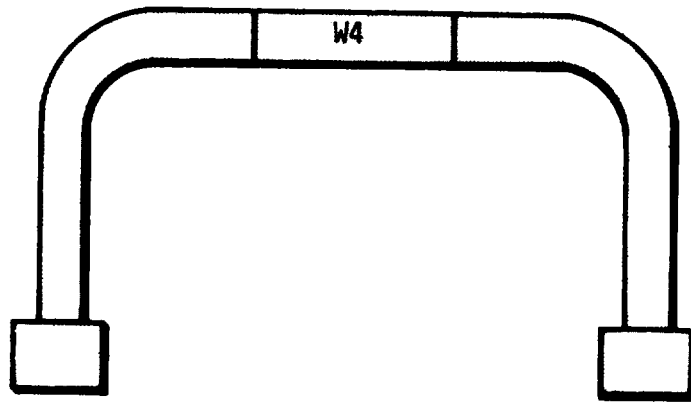

FLTS CABLE W4

SECTION V
MAINTENANCE PROCEDURES

<u>SECTION CONTENTS</u>	<u>PAGE</u>
GENERAL	3-14
OPERATIONAL SELF-TEST	3-15
OPERATIONAL SELF-TEST CHART	3-18
CM SET TEST	3-21
FLTS SHUT DOWN	3-21

GENERAL

3-10. Maintenance procedures at the AVUM level are limited to an operational self-test, replacing lamps and testing and replacing cables.

OPERATIONAL SELF-TEST

3-11. Self-test shall performed at the site of the first AN/ALQ-136(V)1 CM set to be tested that day and as required. The self-test requires +28 V power from CM set LRU-1. When the CM set is used as the +28 V source to the FLTS, connect an external +28 V source to the aircraft. Connect as shown, for FLTS self-test at the flight line. Refer to table 3-1 for self-test setup procedures.

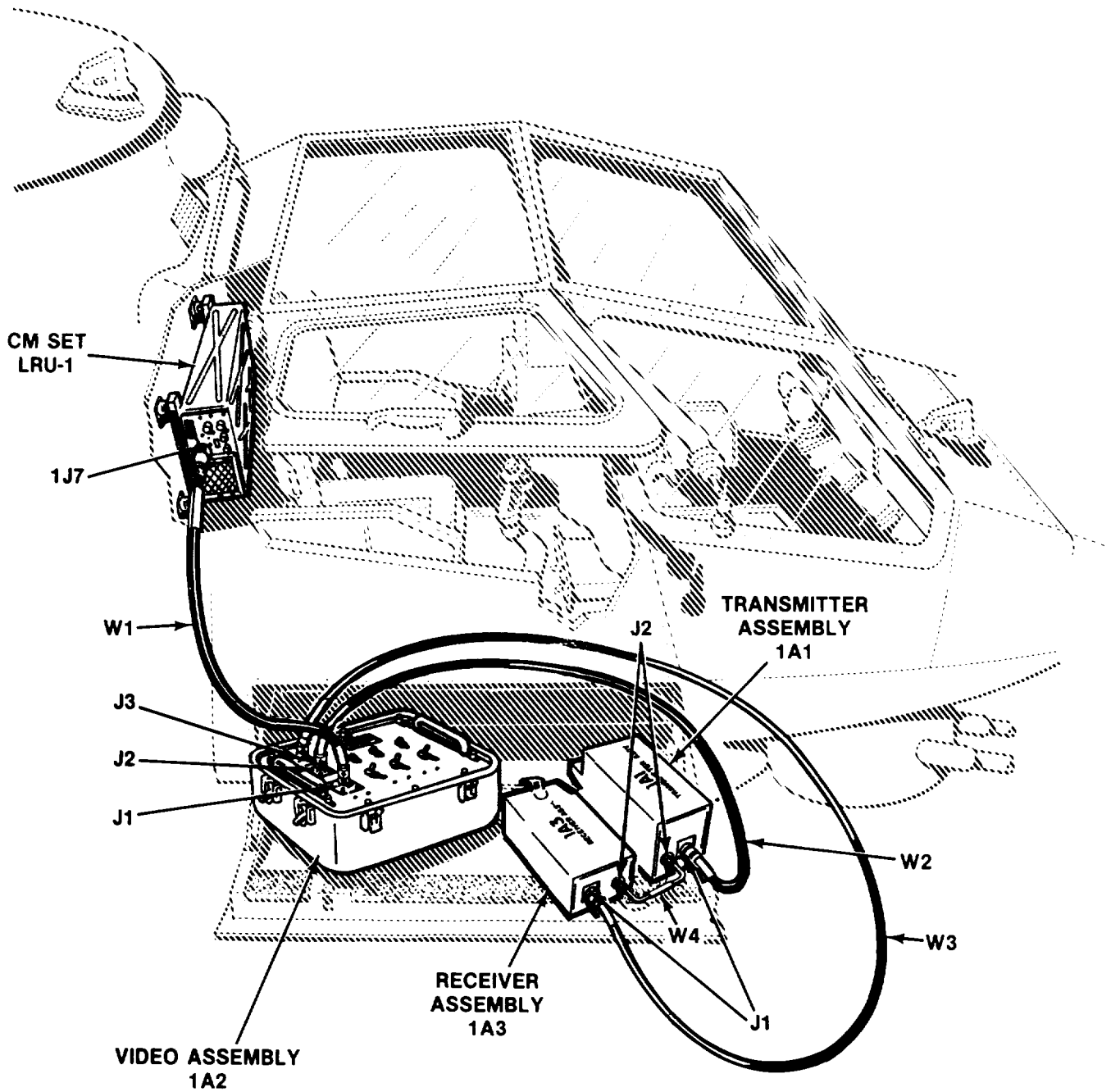

OPERATIONAL SELF-TEST (Continued)

TABLE 3-1. SELF-TEST SETUP PROCEDURES

	PROCEDURE
1	Remove cover of FLTS.
2	Remove transmitter 1A1 and receiver 1A3 assemblies from the cover, and place down on ammo bay hatch cover.
3	Set ON/PWR switch to PWR (off).
4	Set STBY/OPR switch to STBY.
5	Remove cables W1, W2, W3 and W4 from the cover.
6	Connect cable W3 between video assembly 1A2 J3 and receiver assembly 1A3 J1.
7	Connect cable W2 between video assembly 1A2 J2 and transmitter assembly 1A1 J1.
8	Connect cable W1 between video assembly 1A2 J1 and AN/ALQ-136(V)1 LRU-1 1J7.
<p>C A U T I O N</p> <p>Semirigid cable W4 is easily damaged. Do not bend cable W4.</p>	
9	Connect cable W4 between transmitter assembly 1A1 J2 and receiver assembly 1A3 J2.
<p>(This causes the transmitter assembly to route an attenuated RF signal into the receiver assembly, simulating an operational set-up.)</p>	
10	Set CM set LRU-3 OPR/STBY/OFF switch to STBY (refer to TM 11-5865-202-12.)

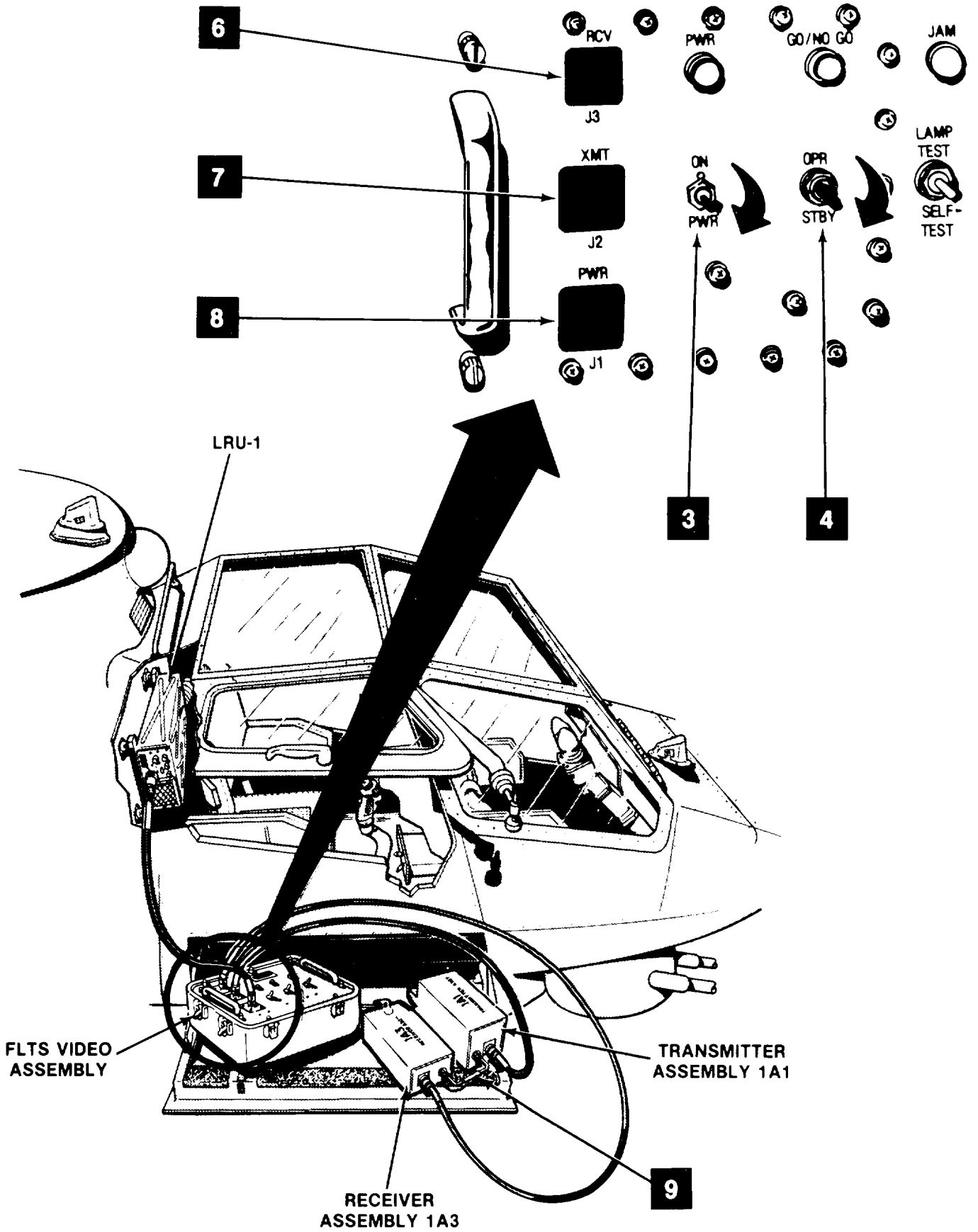

OPERATIONAL SELF-TEST (Continued)

The following pages contain self-test procedures. Please read them carefully and follow the directions. If you reach a point where the obtained results do not agree with the expected results listed, refer to the same step number in paragraph 3-7 for troubleshooting procedure; fill out and submit DA Form 2404.

EQUIPMENT INSPECTION AND MAINTENANCE WORKSHEET											
For use of this form, see TM 38-750, the proponent agency is the Office of the Deputy Chief of Staff for Logistics.											
1. ORGANIZATION 2ND SIGNAL BRIGADE					2. NOMENCLATURE AND MODEL COUNTERMEASURES SET AN/ALQ-136(V)1						
3. REGISTRATION/SERIAL/FSN		4a. MILES		b. HOURS		c. ROUNDS FIRED		d. HOT STARTS	5. DATE 13 JUN	6. TYPE INSPECTION PMCS	
7. APPLICABLE REFERENCE											
TM NUMBER TM 6625-288512			TM DATE			TM NUMBER			TM DATE		
INSTRUCTIONS - Perform each check listed in the TM applicable to the inspection performed. Following the sequence listed in pertinent TM, complete form as follows: COLUMN a - Enter TM item number, COLUMN b - Enter the applicable condition status symbol, COLUMN c - Enter deficiencies and shortcomings. COLUMN d - Show corrective action for deficiency or shortcoming listed in Column c. COLUMN e - Individual ascertaining completed corrective action initial in this column.											
ALL INSPECTIONS AND EQUIPMENT CONDITIONS RECORDED ON THIS FORM HAVE BEEN DETERMINED IN ACCORDANCE WITH DIAGNOSTIC PROCEDURES AND STANDARDS IN THE TM CITED HEREON.											
9a. SIGNATURE (Person(s) performing inspection) <i>David Franklin</i>			9b. TIME 0920 HOURS		9c. SIGNATURE (Maintenance Supervisor)			9d. TIME	10. MANHOURS REQUIRED		
TM ITEM NO.	STATUS	DEFICIENCIES AND SHORTCOMINGS			CORRECTIVE ACTION			INITIAL WHEN CORRECTED			
11		POWER FUSE FAILED			REPLACE FUSE			DWF			

DA FORM 2404
1 JAN 66

OPERATIONAL SELF-TEST CHART

3-12. Each of the column entries used in the operational self-test chart is explained below.

- a. Column 1, ITEM NO. - numbers the checks and services to be performed in order. This column is also used as a source of item numbers on DA Form 2404.
- b. Column 2, ITEM TO BE INSPECTED - identifies which part of the system is to be inspected and the procedure to follow.
- c. Column 3, EXPECTED RESULT - explains how the system is expected to perform.

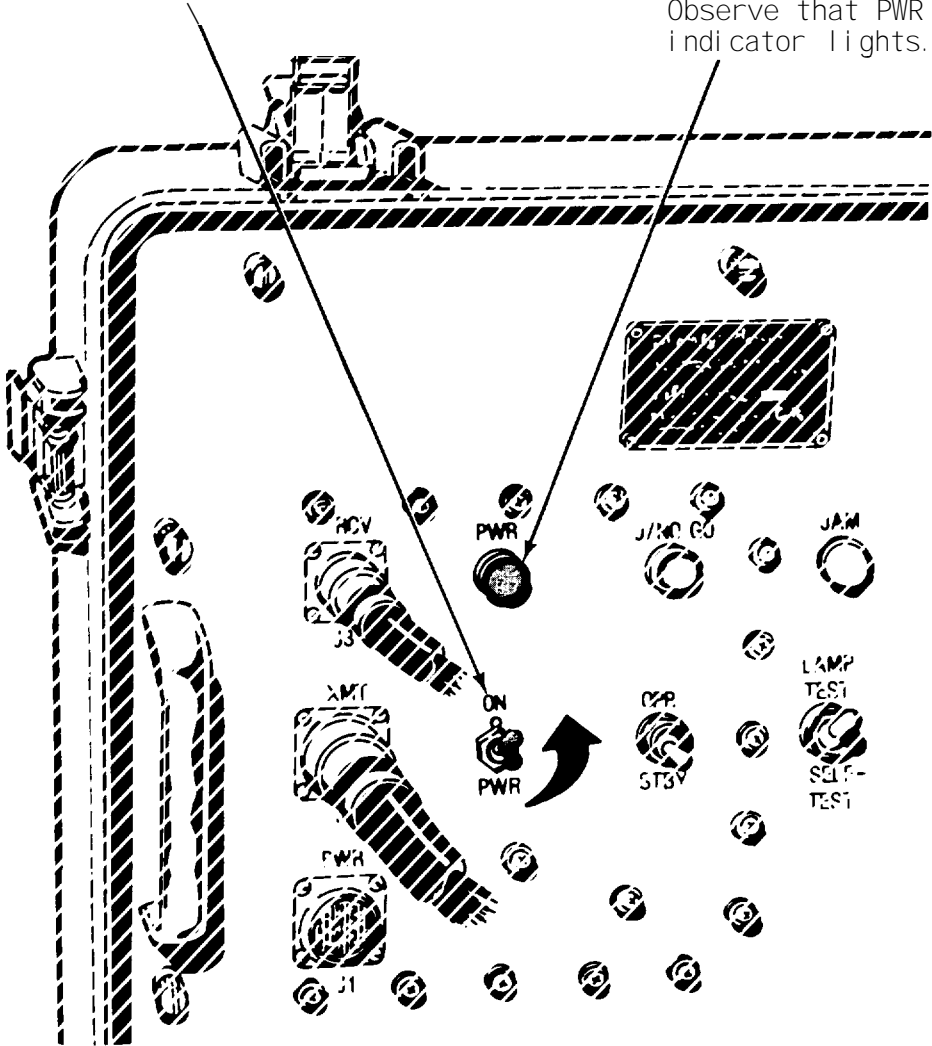
ITEM NO.	ITEM TO BE TESTED	EXPECTED RESULT
1.	<p>FLTS power</p> <p>Referring to CM set manual , turn on aircraft power.</p> <p>Set ON/PWR switch to ON.</p>	<p>Observe that PWR indicator lights.</p> 

OPERATIONAL SELF-TEST CHART (Continued)

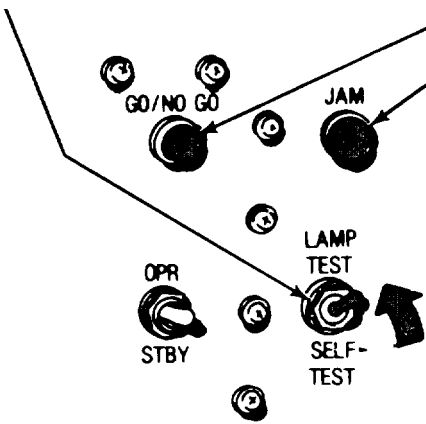
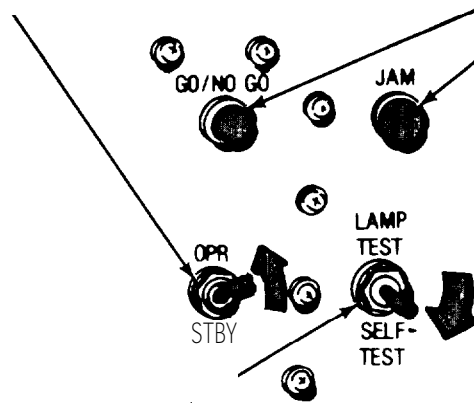
ITEM NO.	ITEM TO BE TESTED	EXPECTED RESULT
2.	<p>Lamps.</p> <p>Set LAMP TEST/SELF-TEST momentary switch to LAMP TEST.</p> <p>(Release switch).</p> 	<p>OBSERVE: GO/NO GO and JAM indicators light.</p>
3.	<p>Set STBY/OPR switch to OPR.</p>  <p>Set LAMP TEST/SELF-TEST switch to SELF-TEST position.</p> <p>(Release switch).</p>	<p>OBSERVE: GO/NO GO and JAM indicators light.</p> <p>This completes the self-testing of the FLTS; disconnect cable W4 and store it in the FLTS cover.</p>

CM SET TEST

3-13. Perform flight line test of CM set per instructions contained in chapter 3 of TM 11-5865-202-12.

FLTS SHUT DOWN

- 3-14. Secure from test by performing the following additional steps:
- a. Set STBY/OPR toggle to STBY.
 - b. Set ON/PWR toggle to PWR (off).
 - c. Turn off CM set in accordance with TM 11-5865-202-12, chapter 3.
 - d. Disconnect cables W1, W2, and W3.
 - e. Reinstall transmitter 1A1 and receiver 1A3 assemblies in the cover of the FLTS.
 - f. Place the cables in storage space provided in the cover of the FLTS.
 - g. Reinstall cover of the FLTS on the video assembly 1A2.

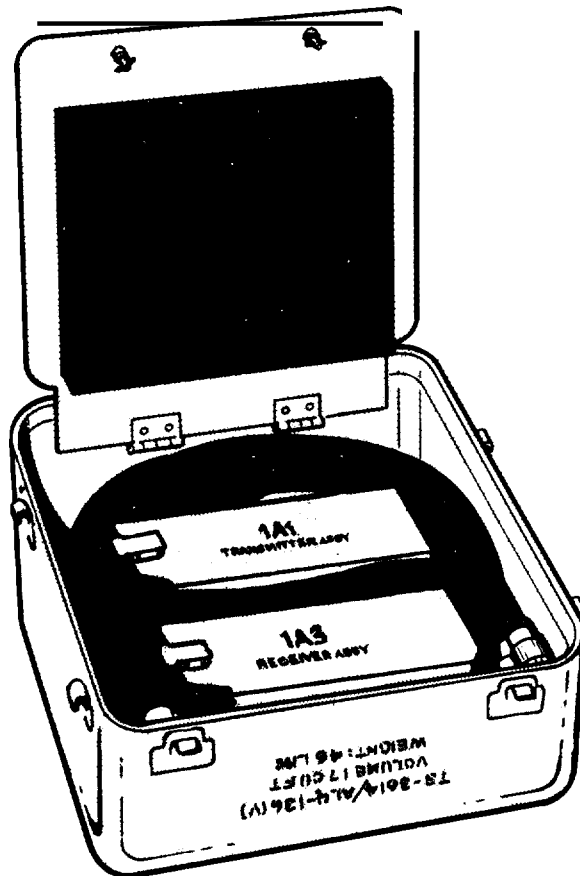

SECTION VI

PREPARATION FOR STORAGE OR SHIPMENT

<u>SECTION CONTENTS</u>	<u>PAGE</u>
SECURITY PROCEDURES.....	3-22
ADMINISTRATIVE STORAGE.....	3-22
INTERMEDIATE AND LONG TERM STORAGE.....	3-22

SECURITY PROCEDURES

3-15. The FLTS is unclassified and requires no special security precautions.

ADMINISTRATIVE STORAGE

3-16. When storage is only for a short term, 1 to 45 days, the FLTS may be stored in its combination case. Store the set indoors in a safe area where it will be protected from damage or adverse environmental factors such as water or extreme dust.

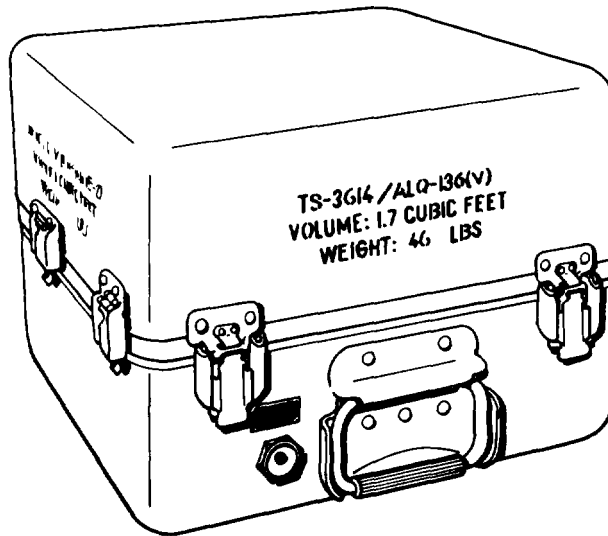

INTERMEDIATE AND LONG TERM STORAGE

3-17. For intermediate storage (46 to 180 days) or long term or flyable storage (180 days or more), it is recommended that the FLTS be stored in its combination case, and packed securely in its original shipping containers, using all original packing materials, corner braces, etc.

A P P E N D I X A

R E F E R E N C E S

A-1. PUBLICATIONS INDEXES

The following indexes should be consulted frequently for latest changes or revisions-of references given in this appendix and for new publications relating to material covered in this manual.

Consolidated Index of Army Publications and Blank Forms DA Pam 310-1

A-2. FORMS AND RECORDS

Recommended Changes to Equipment Technical Publications DA Form 2028

Discrepancy in Shipment Report (DISREP) SF 361

Report of Discrepancy (ROD) SF 364

Quality Deficiency Report SF 368

A-3. OTHER PUBLICATIONS

The following publications contain information pertinent to this material and associated equipment.

a. General

Preservation, Packaging and Packing Material, Supplies and Equipment Used by Army SB 38-100

The Army Maintenance Management System (TAMMS) TM 38-750

b. Maintenance

Administrative Storage Requirements TM 740-90-1

c. Related Publications

Packaging and Handling AR 700-58

Army Shipping Documents AR 725-5

Procedures for Destruction of Electronics Materiel to Prevent Enemy Use (Electronics Command) TM 750-244-2



OTHER PUBLICATIONS (Continued)

Operator's and Aviation Unit Maintenance Manual Counter-
measures Set AN/ALQ-136(V)1 (NSN 5865-01-127-8980) TM 11-5865-202-12

Aviation Unit maintenance Repair Parts and Special Tools List for
Test Set, Countermeasures Set TS-3614/ALQ-136(V)
(NSN 6625-01-121-8993) TM 11-6625-2885-20P

APPENDIX B

MAINTENANCE ALLOCATION

SECTION I

INTRODUCTION

B-1. MAINTENANCE ALLOCATION CHART

a. This Maintenance Allocation Chart (MAC) assigns maintenance functions in accordance with the Three Levels of Maintenance concept for Army Aviation. These maintenance levels (categories) -- Aviation Unit Maintenance (AVUM), Aviation Intermediate Maintenance (AVIM), and Depot Maintenance -- are depicted on the MAC as:

AVUM, which corresponds to an O Code in the Repair Parts and Special Tools List (RPSTL)

AVIM, which corresponds to an F Code in the Repair Parts and Special Tools List (RPSTL)

DEPOT, which corresponds to a D Code in the Repair Parts and Special Tools List (RPSTL).

b. The maintenance to be performed below depot and in the field is described as follows:

(1) Aviation Unit Maintenance (AVUM) activities will be staffed and equipped to perform high frequency "On-Aircraft" maintenance tasks required to retain or return aircraft systems to a serviceable condition. The maintenance capability of the AVUM will be governed by the Maintenance Allocation Chart (MAC) and limited by the amount and complexity of ground support equipment (GSE), facilities required, authorized manning strength, and critical skills available. The range and quantity of authorized spare modules/components will be consistent with the mobility requirements dictated by the air mobility concept. (Assignments of maintenance tasks to divisional company size aviation units will consider the overall maintenance capability of the division, the requirement to conserve personnel and equipment resources, and air mobility requirements.)

(a) Company Size Aviation Units: Perform those tasks which consist primarily of preventive maintenance and maintenance repair and replacement functions associated with sustaining a high level of aircraft operational readiness. Perform maintenance inspections and servicing to include preflight, daily, intermediate, periodic (or phased), and special inspections as authorized by the MAC or higher headquarters. Identify the cause of equipment/system malfunctions using applicable technical manual troubleshooting instructions, built-in-test equipment (BITE), installed aircraft instruments, or test, measurement, and diagnostic equipment (TMDE). Replace worn or damaged modules/components that, do not require complex adjustments or system alignment and which can be removed/installed with available skills, tools, and ground support equipment. Perform operational and continuity checks and make minor repairs

MAINTENANCE ALLOCATION CHART (Continued)

to the electrical system. Inspect, service and make operational, capacity, and pressure checks to hydraulic systems. Perform servicing, functional adjustments, and minor repair/replacement to the flight control, propulsion, power train, and fuel systems. Accomplish air frame repair that does not require extensive disassembly, jiggling, or alignment. The manufacture of air frame parts will be limited to those items which can be fabricated with tools and equipment found in current air mobile tool and shop sets. Evacuate unserviceable modules/components and end items beyond the repair capability of AVUM to the supporting AVIM.

(b) Less than Company Size Aviation Units: Aviation Elements organic to brigade, group, battalion headquarters, and detachment size units are normally small and have less than ten aircraft assigned. Maintenance tasks performed by these units will be those which can be accomplished by the aircraft crew chief or assigned aircraft repair person and will normally be limited to preventive maintenance, inspections, servicing, spot painting, stop drilling, application of nonstress patches, minor adjustments, module/component fault diagnosis, and replacement of selected modules/components. Repair functions will normally be accomplished by the supporting AVIM unit.

(2) Aviation Intermediate Maintenance (AVIM) provides mobile, responsive "One-Stop" maintenance support. (Maintenance functions which are not conducive to sustaining air mobility will be assigned to depot maintenance.) AVIM may perform all maintenance functions authorized to be done at AVUM. Repair of equipment for return to user will emphasize support or operational readiness requirements. Authorized maintenance includes replacement and repair of modules/components and end items which can be accomplished efficiently with available skills, tools, and equipment. AVIM establishes the Direct Exchange (DX) program for AVUM units by repairing selected items for return to stock when such repairs cannot be accomplished at the AVUM level. The AVIM level inspects, troubleshoots, performs diagnostic tests, repairs, adjusts, calibrates, and aligns aircraft system modules/components. AVIM units will have capability to determine the serviceability of specified modules/components removed prior to the expiration of the Time Between Overhaul (TBO) or finite life. Module/component disassembly and repair will support the DX program and will normally be limited to tasks requiring cleaning and the replacement of seals, fittings, and items of common hardware. Air frame repair and fabrication of parts will be limited to those maintenance tasks which can be performed with available tools and test equipment. Unserviceable reparable modules/components and end items which are beyond the capability of AVIM to repair will be evacuated to Depot Maintenance. AVIM will perform aircraft weight and balance inspections and other special inspections which exceed AVUM capability. Provides quick response maintenance support, including aircraft recovery and air evacuation, on-the-job training, and technical assistance through the use of mobile maintenance contact teams. Maintains authorized operational readiness float aircraft. Provides collection and classification services for serviceable/unserviceable material. Operates a cannibalization activity in accordance with AR 750-2. (The aircraft maintenance company within the maintenance battalion of a division will perform AVIM functions consistent with air mobility requirements and conservation of personnel and equipment resources. Additional intermediate maintenance support will be provided by the supporting nondivisional AVIM unit.)

B-2. USE OF THE MAINTENANCE ALLOCATION CHART (SECTION II)

a. The Maintenance Allocation Chart assigns maintenance functions to the lowest category of maintenance based on past experience and the following considerations:

- (1) Skills available.
- (2) Work time required.
- (3) Tools and test equipment required and/or available.

b. Only the lowest category of maintenance authorized to perform a maintenance function is indicated. If the lowest maintenance category cannot perform all tasks of any single maintenance function (e.g., test, repair), then the higher maintenance level(s) that can accomplish additional tasks will also be indicated.

c. A maintenance function assigned to a maintenance category will automatically be authorized to be performed at any higher maintenance category.

d. A maintenance function that cannot be performed at the assigned category of maintenance for any reason may be evacuated to the next higher maintenance category. Higher maintenance categories will perform the maintenance functions of lower maintenance categories when required or directed by the commander that has the authority to direct such tasking.

e. The assignment of a maintenance function will not be construed as authorization to carry the related repair parts or spares in stock. Information to requisition or otherwise secure the necessary repair parts will be as specified in the associated Repair Parts and Special Tools List (RPSTL).

f. Normally there will be no deviation from the assigned level of maintenance. In cases of operational necessity, maintenance functions assigned to a maintenance level may, on a one-time basis and at the request of the lower maintenance level, be specifically authorized by the maintenance officer of the level of maintenance to which the function is assigned. The special tools, equipment, etc. required by the lower level of maintenance to perform this function will be furnished by the maintenance level to which the function is assigned. This transfer of a maintenance function to a lower maintenance level does not relieve the higher maintenance level of the responsibility for the function. The higher level of maintenance will provide technical supervision and inspection of the function being performed at the lower level.

g. Changes to the Maintenance Allocation Chart will be based on continuing evaluation and analysis by responsible technical personnel and on reports received from field activities.

B-3. MAINTENANCE FUNCTIONS

Maintenance functions will be limited to and defined as follows:

a. Inspect. To determine the serviceability of an item by comparing its physical, mechanical, and/or electrical characteristics with established standards through examination.

b. Test. To verify serviceability by measuring the mechanical or electrical characteristics of an item and comparing those characteristics with prescribed standards.

c. Service. Operations required periodically to keep an item in proper operating condition, i.e., to clean (includes decontaminate, when required), to preserve, to drain, to paint, or to replenish fuel, lubricants, chemical fluids, or gases.

d. Adjust. To maintain, within prescribed limits, by bringing into proper or exact position, or by setting the operating characteristics to specified parameters.

e. Align. To adjust specified variable elements of an item to bring about optimum or desired performance.

f. Calibrate. To determine and cause corrections to be made or to be adjusted on instruments or test, measuring, and diagnostic equipment used in precision measurement. Consists of comparisons of two instruments, one of which is a certified standard of known accuracy, to detect and adjust any discrepancy in the accuracy of the instrument being compared.

g. Install. The act of emplacing, seating, or fixing into position an item, part, module (component or assembly) in a manner to allow the proper functioning of an equipment or system.

h. Replace. The act of substituting a serviceable like type part, sub-assembly, or module (component or assembly) for an unserviceable counterpart.

i. Repair. The application of maintenance services¹ or other maintenance actions² to restore serviceability to an item by correcting specific damage, fault, malfunction, or failure in a part, subassembly, module (component or assembly), end item, or system.

j. Overhaul. That maintenance effort (service/action) necessary to restore an item to a completely serviceable/operational condition as prescribed by maintenance standards in appropriate technical publications (i.e., DMWR). Overhaul is normally the highest degree of maintenance performed by the Army. Overhaul does not normally return an item to like new condition.

¹Services -- inspect, test, service, adjust, align, calibrate, or replace.

²Actions -- welding, grinding, riveting, straightening, facing, remachining, or resurfacing.

k. Rebuild. Consists of those services/actions necessary for the restoration of unserviceable equipment to a like new condition in accordance with original manufacturing standards. Rebuild is the highest degree of materiel maintenance applied to Army equipment. The rebuild operation includes the act of returning to zero those age measurements (hours/miles, etc.) considered in classifying Army equipments/components.

B-4. GROUP NUMBER AND COMPONENT/ASSEMBLY (COLUMNS 1 AND 2, RESPECTIVELY)

a. Group Number (Column 1). Column 1 lists group numbers, the purpose of which is to identify components, assemblies, subassemblies, and modules with the next higher assembly.

b. Component/Assembly (Column 2). Column 2 contains the noun names of components, assemblies, subassemblies, and modules for which maintenance is authorized.

B-5. MAINTENANCE FUNCTION (COLUMN 3)

Column 3 lists the functions to be performed on the items listed in column 2.

B-6. MAINTENANCE CATEGORIES AND WORK TIMES (COLUMN 4)

The maintenance categories (levels) AVUM, AVIM, and DEPOT are listed on the Maintenance Allocation Chart with individual columns that include the work times for maintenance functions at each maintenance level. Work time presentations such as "0.1" indicate the average time it requires a maintenance level to perform a specified maintenance function. If a work time has not been established, the columnar presentation shall indicate "-- --". Maintenance levels higher than the level of maintenance indicated are authorized to perform the indicated function.

B-7. TOOLS AND TEST EQUIPMENT (COLUMN 5 AND SECTION III)

Common tool sets (not individual tools), special tools, test, and support equipment required to perform maintenance functions are listed alphabetically in Section III with a reference number to permit cross-referencing to column 5 in the MAC. In addition, the maintenance category authorized to use the device is listed along with the item National Stock Number (NSN) and, if applicable, the tool number to aid in identifying the tool/device.

B-8. REMARKS (COLUMN 6 AND SECTION IV)

Remarks (identified by an alphabetic code in column 6) and other notes (identified by a number in parentheses in the applicable column) are listed in Section IV to provide a ready reference to the definition of the remark/note.

SECTION II
MAINTENANCE ALLOCATION CHART

(1) GROUP NUMBER	(2) COMPONENT ASSEMBLY	MAINTENANCE FUNCTION	(4) MAINTENANCE CATEGORY			TOOLS AND EQPT.	(6) REMARKS
			AVUM	AVIM	DEPOT		
00	TEST SET, COUNTERMEASURES SET, TS-3614/ALQ-136(V)	Inspect	0.1			1	A
		Test	0.2			2 thru 10	
		Test		0.25		3 thru 11	B
		Test			1.0		
		Replace	0.1			2 thru 10	
		Adjust		0.25			
01	TRANSMITTER ASSEMBLY	Repair	0.2			2 thru 10	
		Repair		0.75		2 thru 10	C
		Repair			6.0	2 thru 11	D
		Inspect					B
		Test		0.1		2 thru 10	
		Test		0.2		11	
02	RECEIVER ASSEMBLY	Test			0.5		B
		Replace		0.1		2 thru 10	
		Adjust		0.5		2 thru 11	
		Repair			3.0		B
		Inspect					B
		Test		0.1		2, 3, 4, 5, 8	
0201	POWER LEVEL DETECTOR	Test			0.5	11	
		Replace		0.1		2, 3, 4, 5, 8	
		Adjust		0.5		2, 3, 4, 5, 8, 11	
		Repair			4.0		B
		Inspect					B
		Test		0.2		11	
020101	CCA, POWER LEVEL DETECTOR	Test			0.1	2	B
		Replace			0.2	2, 11	B
		Repair			0.5		B
		Inspect					B
		Test		0.2		11	
		Test		0.2		2	
03	VIDEO ASSEMBLY	Repair			0.75	2, 11	B
		Inspect					B
		Test		0.1		2, 3, 4, 5	
		Test		0.2		2	
		Replace		0.1			E
		Repair	0.2			2, 3, 4, 5	F
0301	CCA, PULSE GENERATOR	Repair		2.0			
		Test			0.2	2	
		Test			0.2	11	B
0302	CCA, CS-PULSE CONTROL	Repair			4.0	2, 11	B
		Replace		0.2		2	
		Test			0.2		B
		Repair			4.0	2, 11	B

SECTION III

TOOLS AND TEST EQUIPMENT REQUIREMENTS

TOOLS OR TEST EQUIP REF CODE	MAINTENANCE CATEGORY	NOMENCLATURE	NATIONAL/NATO STOCK NUMBER	TOOL NUMBER
1	AVUM	MULTIMETER; AN/USM-223	6625-00-999-7465	
2	AVIM, DEPOT	TOOL KIT ELECTRONIC EQUIPMENT, TK-105/G	5180-00-610-8177	
3	AVIM, DEPOT	TEST SET, TS-3615/ALQ-136(V)	6625-01-121-8984	
4	AVIM, DEPOT	MULTIMETER, DIGITAL AN/PSM-45	6625-01-139-2512	
5	AVIM, DEPOT	OSCILLOSCOPE, AN/USM-281C	6625-00-106-9622	
6	AVIM, DEPOT	TEST SET, RADIO FREQUENCY POWER TS-3793/U (HP MODEL 436A)	6625-01-075-0261	
		<p style="text-align: center;">NOTE</p> <p>HP MODEL 435A (NSN 6625-00-449-9167) or 4356 (NSN 6625-01-114-0085) MAY BE USED UNTIL THE TS-3793/U BECOMES AVAILABLE</p>		
7	AVIM, DEPOT	POWER SENSOR, HEWLETT-PACKARD MODEL 8481A	6625-00-354-9762	
8	AVIM, DEPOT	POWER, SUPPLY, PP-1104C/G	6130-00-542-6385	
9	AVIM, DEPOT	COUNTER, MICROWAVE FREQUENCY TD-1225A(V)2/U	6625-01-121-6934	
10	AVIM, DEPOT	RF ADAPTOR, HEWLETT, PACKARD MODEL P281B, OPT 013 (2 REQUIRED)	5985-00-004-0105	
11	DEPOT	DEPOT TEST FIXTURES		

SECTION IV
R E M A R K S

REMARKS	REFERENCE CODE
A	Self test and lamp test in aircraft.
B	Depot test fixtures, skill, and facilities rewired.
C	Repair limited to replacement of cables, W1, W2, W3, and W4.
D	Repair limited to video assembly and replacement of transmitter assembly and receiver assembly.
E	Repair limited to replacement of lamps.
F	Repair includes replacement of power supply modules, over voltage protector, lampholders, connectors, circuit breaker, RFI filters, and switches which are throwaway items.

APPENDIX C

COMPONENTS OF END ITEM LIST

SECTION I

INTRODUCTION

C-1. SCOPE

This appendix lists integral components of and basic issue items for the TS-3614/ALQ-136(V) to help you inventory items required for safe and efficient operation.

C-2. GENERAL

The Components of End Item are illustrated and described in Section II Components of the End Item. This listing is for informational purposes only, and is not authority to requisition replacements. These items are part of the end item, but are removed and separately packaged for transportation or shipment. As part of the end item, these items must be with the end item whenever it is issued or transferred between property accounts. Illustrations are furnished to assist you in identifying the items. There are no Basic-Issue Items (BII) required for the FLTS.

C-3. EXPLANATION OF COLUMNS

- a. Column (1) - Illustration. This column contains the item number, the number used to identify item called out in the illustration.
- b. Column (2) - National Stock Number. Indicates the National stock number assigned to the item and will be used for requisitioning purposes.
- c. Column (3) - Description. Indicates the Federal item name and, if required, a minimum description to identify and locate the item. The last line for each item indicates the FSCM (in parentheses) followed by the part number.
- d. Column (4) - Unit of Measure (U/M). Indicates the measure used in performing the actual operational/maintenance function. This measure is expressed by a two-character alphabetical abbreviation (e.g., ea, in, pr).
- e. Column (5) - Quantity required (Qty reqd). Indicates the quantity of the item authorized to be used with/on the equipment.

SECTION II. COMPONENTS OF END ITEM

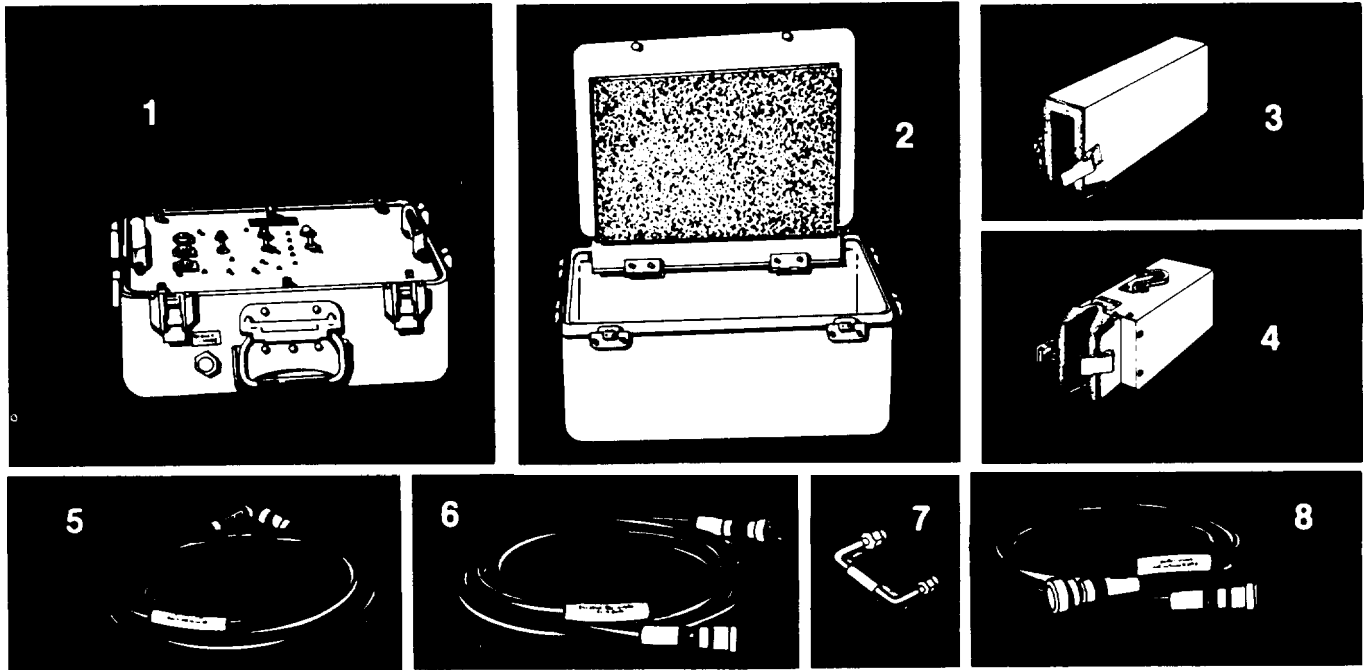

(1) ILLUS NO.	(2) NATIONAL STOCK NUMBER	(3) DESCRIPTION FSCM AND PART NUMBER	(4) U/M	(5) QTY ROD
1	5865-01- 119-7146	VIDEO ASSEMBLY 1A2 (80063) SM-D-919767	EA	1
2		CASE COVER	EA	1
3	5865-01 119-7147	RECEIVER ASSEMBLY 1A3 (80063) SM-D-919768	EA	1
4	5865-01 119-7145	TRANSMITTER ASSEMBLY 1A1 (80063) SM-D-919766	EA	1
5		CABLE ASSEMBLY (W3) (80063) SM-C-920040	EA	1
6		CABLE ASSEMBLY (W2) (80063) SM-C-919772	EA	1
7		CABLE ASSEMBLY (W4) (80063) SM-C-920041	EA	1
8		CABLE ASSEMBLY (W1) (80063) SM-C-919771	EA	1

APPENDIX E
EXPENDABLE SUPPLIES AND
MATERIALS LIST

SECTION I
INTRODUCTION

E-1. SCOPE

This appendix lists expendable supplies and materials you will need to operate and maintain the FLTS. These items are authorized to you by CTA 50-970, Expendable Items (Except Medical, Class V, Repair Parts, and Heraldic Items).

E-2. EXPLANATION OF COLUMNS

a. Column (1) - Item Number. This number is assigned to the entry in the listing and is referenced in the narrative instructions to identify the material (e. g., "Use cleaning compound, item 5, App. D").

b. Column (2) - Level. This column identifies the lowest level of maintenance that requires the listed item.

(enter as applicable)

0 - Aviation Unit Maintenance
F - Direct Support Maintenance

c. Column (3) - National Stock Number. This is the National stock number assigned to the item; use it to request or requisition the item.

d. Column (4) - Description. Indicates the Federal item name and, if required, a description to identify the item. The last line for each item indicates the part number followed by the Federal Supply Code for Manufacturer (FSCM) in parenthesis followed by the part number.

e. Column (5) - Unit of Measure (U/M). Indicates the measure used in performing the actual maintenance function. This measure is expressed by a two-character alphabetic abbreviation (e. g., ea, in, pr). If the unit of measure differs from the unit of issue, requisition the lowest unit of issue that will satisfy your requirements.

SECTION II
EXPENDABLE SUPPLIES AND MATERIALS

(1) ITEM NUMBER	(2) LEVEL	(3) NATIONAL STOCK NUMBER	(4) DESCRIPTION	(5) U/M
1	0		Cloth, lint-free	A/R
2	0		Tri chlorotri fluoroethane	A/R
3	F		Paint, yellow, FED-STD-595 color no. 23538	QT
4	F		Sandpaper	A/R
5	F		Brush, paint	EA
6	F		Brush, wire	EA
7	F		Sealing compound (MIL- S-22473 grade A)	A/R

I N D E X

SUBJECT	PAGE
A	
Abbreviations, list of.....	1-5
Administrative storage.....	1-4, 3-22
C	
Cable Assemblies, location and description.....	1-7, 1-9
schematics.....	3-10
Case cover.....	1-7, 1-8
CM set test.....	3-21
Components of end item.....	C-1
Controls and indicators.....	2-2
D	
Data, Equipment.....	1-10
Deficiencies, packaging and handling.....	1-2
Description of equipment.....	1-7
Destruction of materiel.....	1-4
E	
Equipment improvement recommendation (EIR).....	1-3
End item, components of.....	C-1
Equipment, capabilities.....	1-6
characteristics.....	1-6
description.....	1-7
features.....	1-6
Errors, reporting of.....	i
F	
First aid.....	b
FLTS shut down.....	3-21
Forms, maintenance, records, and reports.....	1-2, A-1
H	
Hand receipt manual.....	1-2
How to use this manual.....	iii
I	
Improvement, recommended.....	i
Indicators, controls.....	2-2

INDEX (Continued)

SUBJECT	PAGE
L	
Location and description of major components	1-7
M	
Major components, location and description	1-7
Maintenance, allocation	B-1
preventive	3-4
procedures	3-14
N	
Navy, address for deficiency report	i
Nomenclature cross reference list	1-4
O	
Operator's controls and indicators	2-1
Operating instructions	2-1
Operation, principles of	1-12
Operational self test	3-15
P	
Procedures, maintenance	3-14
operating	2-1
troubleshooting	3-4
Parts repair	3-1
PMCS	3-4
Preparation for storage or shipment	3-22
Principles of operation	1-12
R	
Receiver assembly, location and description	1-8
Recommended improvement	i
References	A-1
Repair parts and special tools	3-1
Reporting errors	i

I N D E X (Conti nued)

S U B J E C T	P A G E
S	
Safety, care and handling	1-11
Scope of manual	1-1
Security procedures	3-22
Self-test, operational	3-15
Shut down, FLTS	3-21
T	
Technical principles of operation	1-12
Tools, common	3-1, B-7
special	3-1, B-7
Transmitting assembly, location and description	1-8
Troubleshooting:	
procedures	3-4
chart	3-5
Type of manual	1-1
U	
Unpacked equipment, checking of	3-2
Unpacking	3-2
Unsatisfactory equipment, report of	1-2
V	
Video assembly, location and description	1-8
W	
WARNINGS	Inside front cover

By Order of the Secretaries of the Army and the Navy:

Official:

JOHN A. WICKHAM JR.
General, United States Army
Chief of Staff

ROBERT M. JOYCE
Major General, United States Army
The Adjutant General

G. B. SCHICK, JR.
Rear Admiral, United States Navy
Commander, Naval Electronic
Systems Command

Distribution:

To be distributed in accordance with special list.

FILL IN YOUR
UNIT'S ADDRESS

FOLD BACK

DEPARTMENT OF THE ARMY

Commander
US Army Communications-
Electronics Command and Fort Monmouth
ATTN: DRSEL-ME-MP
Fort Monmouth, New Jersey 07703

TEAR ALONG PERFORATED LINE

